



A_SOP

SUM OF PARTS

Modular seating arrangements with limitless combinations
allowing designers the freedom to choose from a series
of well proportioned simple forms to create

A sum of parts...A_SOP



A_SOP

A sum of parts was designed as a response to a gap in our soft seating offering for a locally designed and manufactured modular seating system.

Intended to provide designers and specifiers flexibility of components and configurations for use Front of house, Back of house and everywhere in between.

MATERIALS

Frame – Solid wood frame with multi density high resilience foam

Upholstery – Selected house fabrics - non removable

Base - Black laminated moisture resistant plinth or individual feet

Loose Seat Cushions – 60% Feather 40% microfibre with removable covers

HOUSE FABRICS

Careful consideration has been given to the most suitable fabrics to achieve optimum upholstery outcomes for A_SOP.

Please contact us with any queries regarding alternative COM fabric selections

_MODULES

_SEAT MODULES

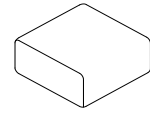

S_750
750W X 750D X 400H

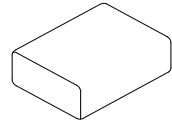

S_1000
1000W X 750D X 400H

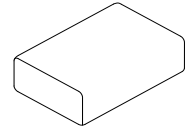

S_1125
1125W X 750D X 400H

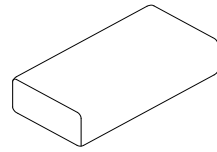

S_1500
1500W X 750D X 400H

_CORNER MODULE



CM_1
1270 X 1040 X 400

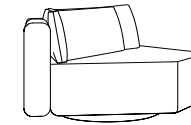

CM_2
1410 X 1210 X 620
*Corner module supplied
with corner back cushion,
1 x loose cushion 500mm x
400mm high*

_BACK MODULES

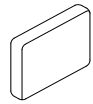

B_750
750W X 150D X 570H

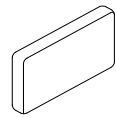

B_1000
1000W X 150D X 570H

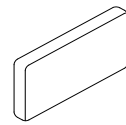

B_1125
1125W X 150D X 570H

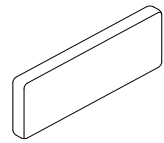

B_1500
1500W X 150D X 570H

_CUSHIONS



C_700
700W X 165D X 400H



C_800
800W X 165D X 400H



C_900
900W X 165D X 400H

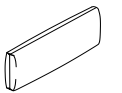

C_1000
1000W X 165D X 400H

_ARM MODULES



A_S750
250W X 750D X 440H

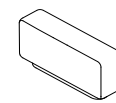

A_S900
250W X 900D X 440H

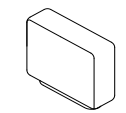

A_H750
250W X 750D X 630H

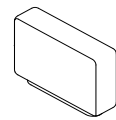

A_H900
250W X 900D X 630H

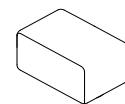

A_W750
500W X 750D X 440H

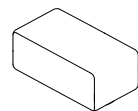

A_W900
500W X 900D X 440H

_TABLES

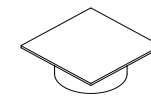

TABLE 1
750W X 750D X 280 H

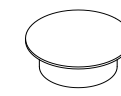

TABLE 2
800 DIA TOP 600 DIA BASE
280 H

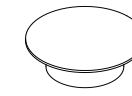

TABLE 3
900 DIA TOP 600 DIA BASE
280 H

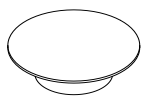

TABLE 4
1000 DIA TOP 600 DIA
BASE 280 H

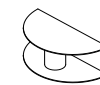
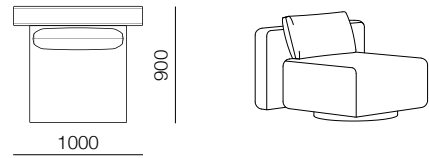
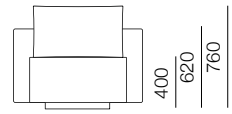

TABLE 5
750W X 375D X 280 H

FAVOURITE SUMS

_1 SEAT



1.11
S_750
B_1000
C_700

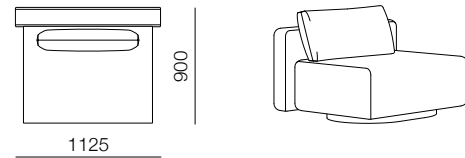
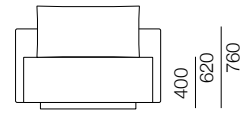

2.12
S_1000
B_1125
C_800

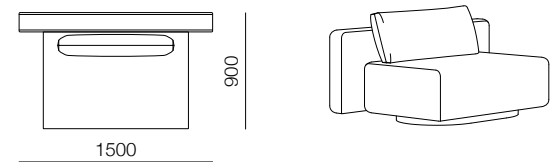
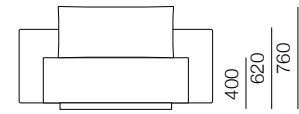

3.11
S_1125
B_1500
C_700

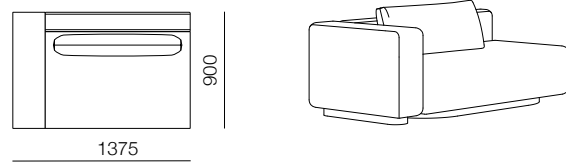
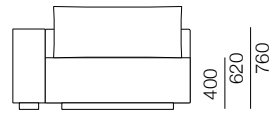

3.14
S_1125 A_H900
B_1125
C_1000

_2 SEAT

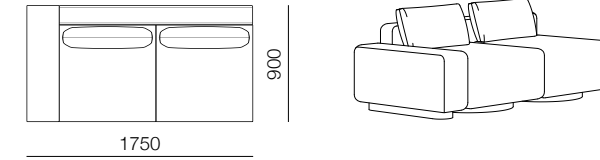
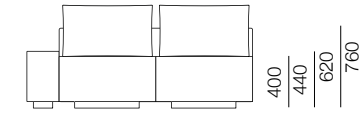

1.19
S_750 A_S900
B_1500
C_700

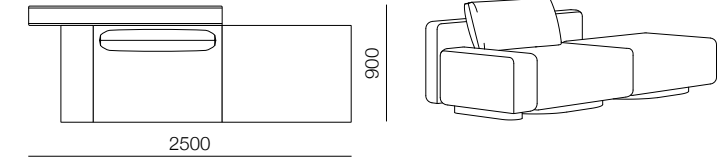
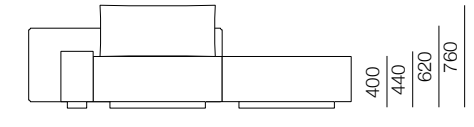

2.25
S_1000 A_S750
B_1500
C_900

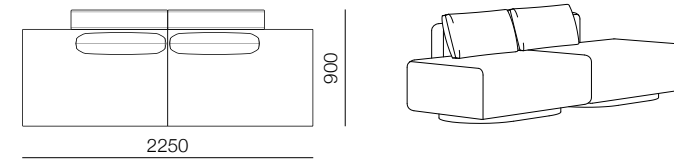
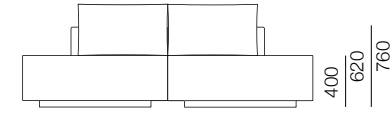

3.15
S_1125
B_750
C_700

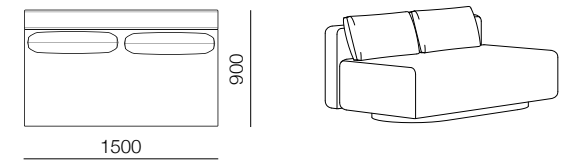
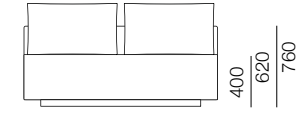

4.18
S_1500
B_1500
C_700

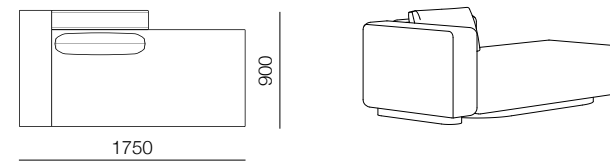
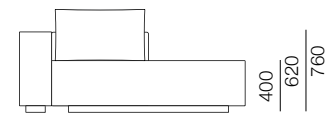

4.19
S_1500 A_H900
B_750
C_700

_ FAVOURITE SUMS

_3 SEAT

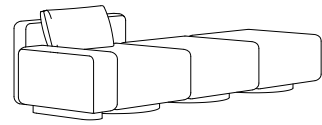
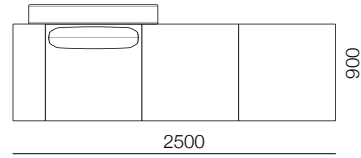
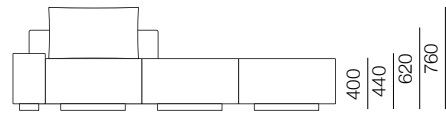

1.24

S_750 A_S750
B_1000
C_700

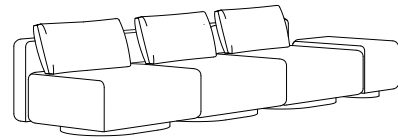
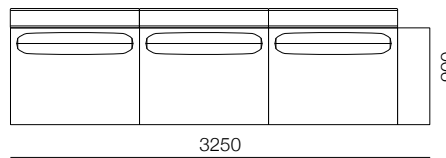
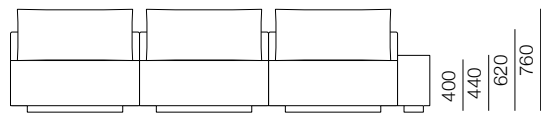

2.32

S_1000 A_S750
B_1000
C_900

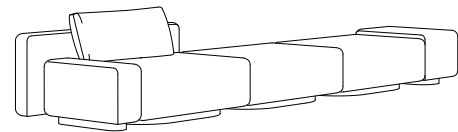
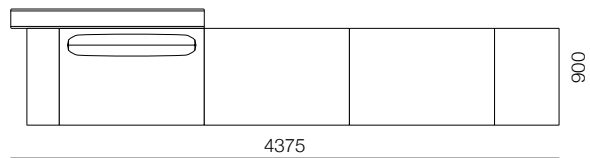
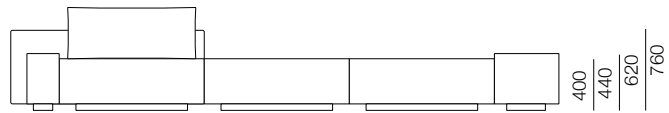

3.52

S_1125 A_S750
B_1500 A_W750
C_1000

_4 SEAT

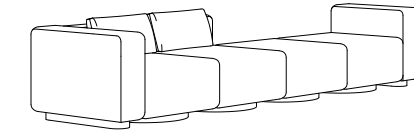
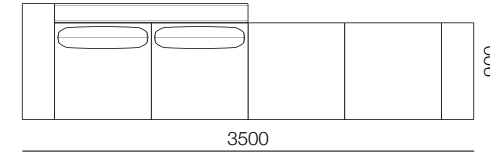
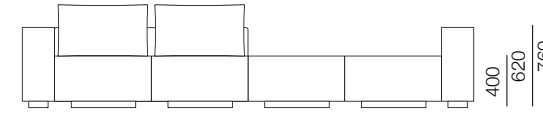

1.58

S_750 A_H750
B_1500 A_H900
C_700

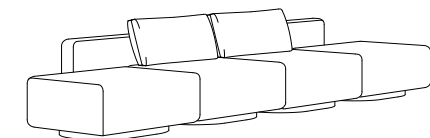
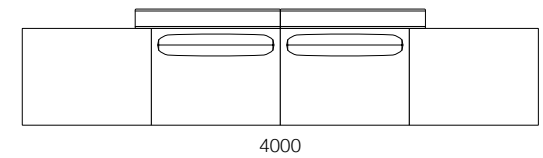
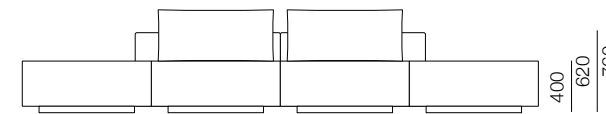

2.58

S_1000
B_1125
C_900

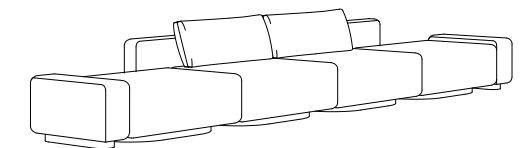
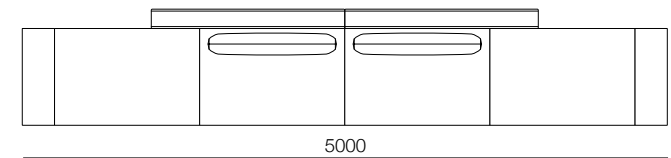
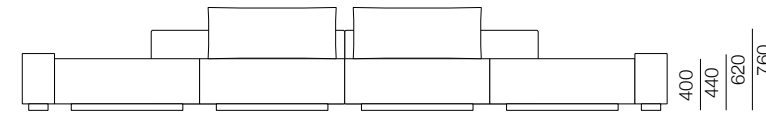

3.67

S_1125 A_S750
B_1500
C_1000

_ FAVOURITE SUMS

_ 4 SEAT

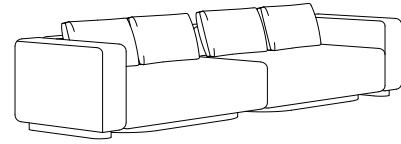
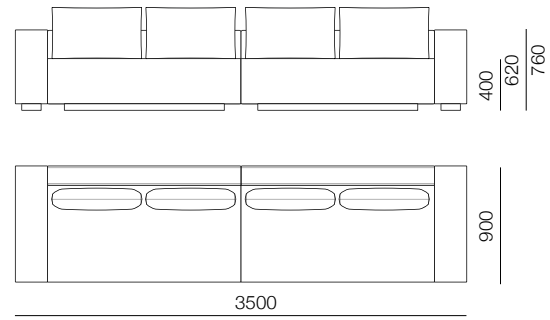

4.35

S_1500 A_H900
B_1500
C_700

_ MODULAR

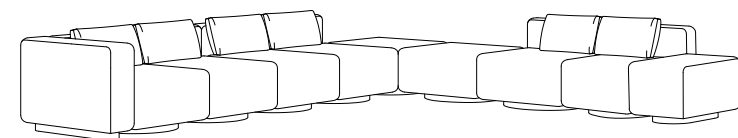
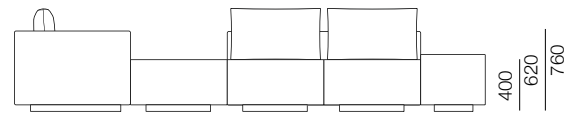
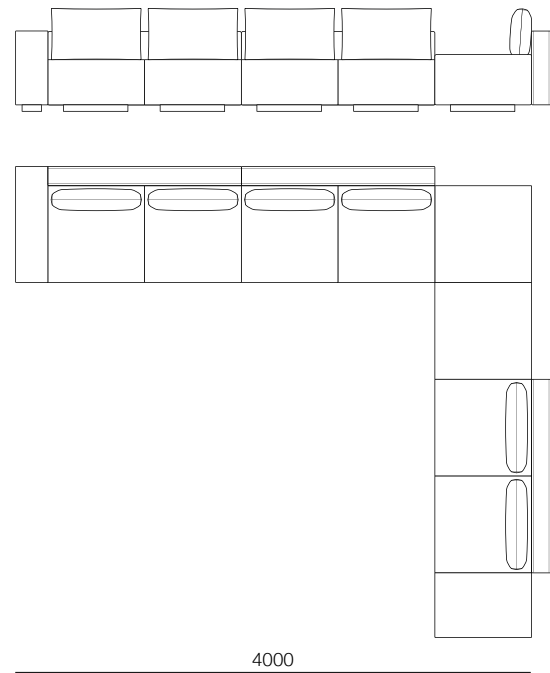

M.21

S_750 A_H900
B_1500 A_W750
C_700

_ MODULAR

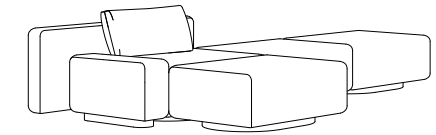
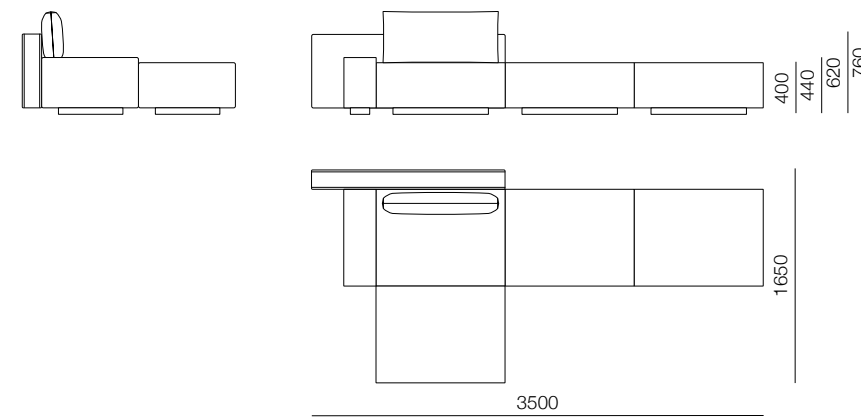

M.32

S_1000 A_S750
B_1500
C_900

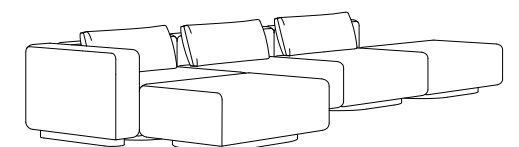
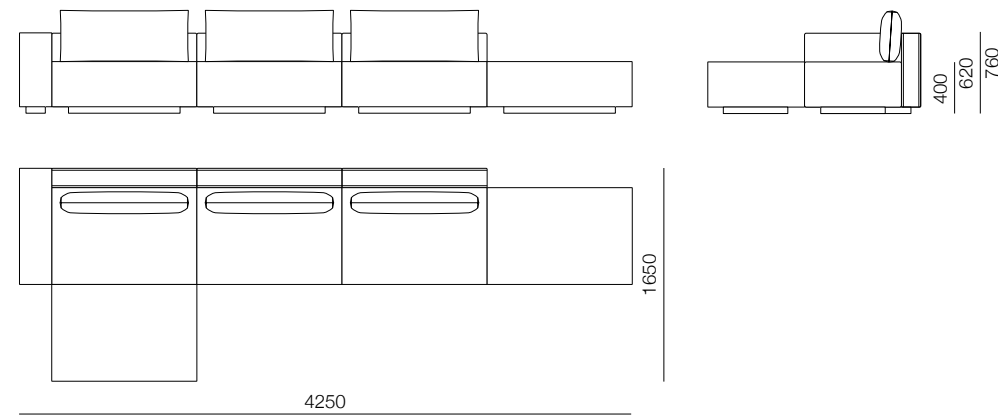

M.45

S_1125 A_H900
B_1125
C_1000

_ FAVOURITE SUMS

_ CORNER MODULAR

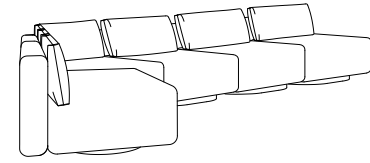
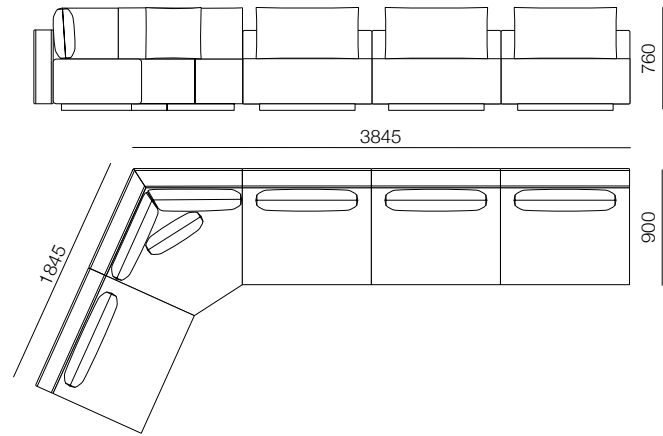

CM.07

S_1000 CM_2
B_1000
C_800

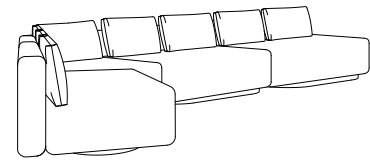
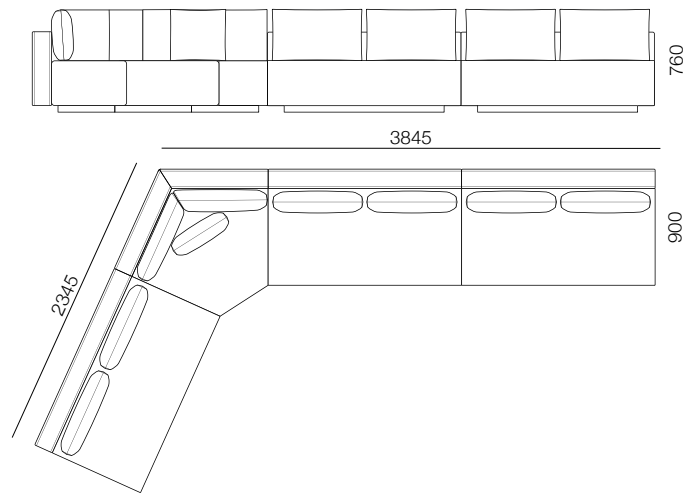

CM.19

S_1500 CM_2
B_1500
C_700



**CHOOSE FROM A LOT MORE SUMS
OR CALCULATE YOUR OWN SUM OF PARTS**

_ COMPOSITIONS_1 SEAT

_750

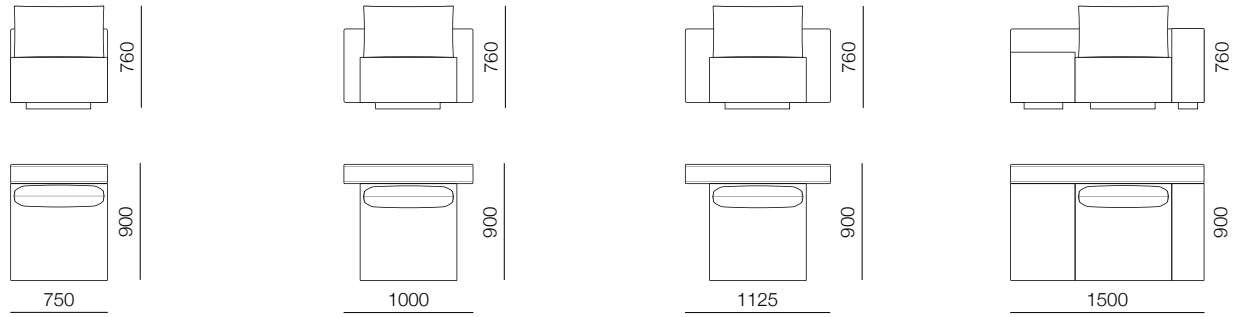

- 1.10**
S_750
B_750
C_700
- 1.11**
S_750
B_1000
C_700
- 1.12**
S_750
B_1125
C_700
- 1.13**
S_750 A_W750
B_1500 A_H750
C_700

_1000

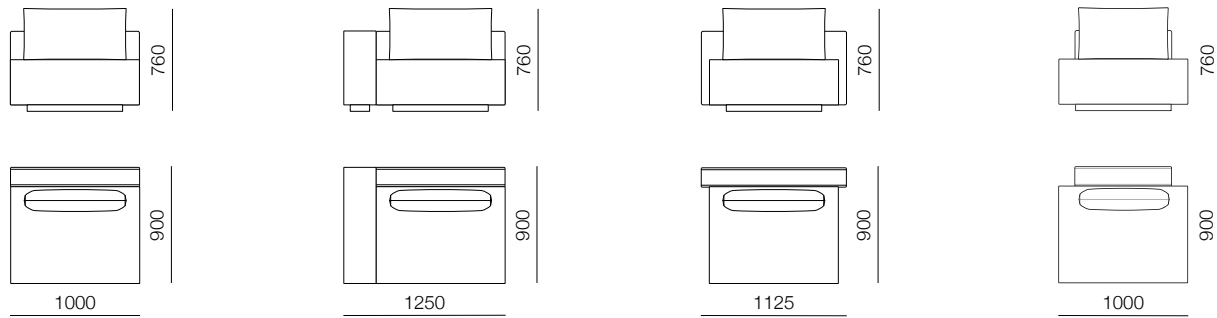

- 2.10**
S_1000
B_1000
C_800
- 2.11**
S_1000 A_H900
B_1000
C_800
- 2.12**
S_1000
B_1125
C_800
- 2.13**
S_1000
B_750
C_700

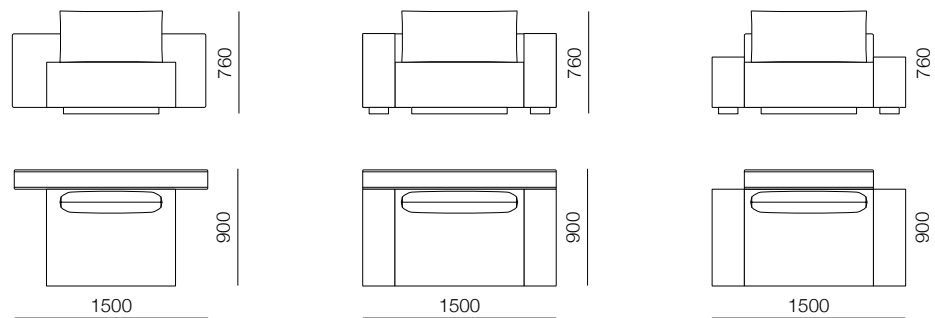

- 2.14**
S_1000
B_1500
C_800
- 2.15**
S_1000 A_H900
B_1500
C_900
- 2.16**
S_1000 A_S750
B_1000
C_900

_ COMPOSITIONS_1 SEAT

_1125

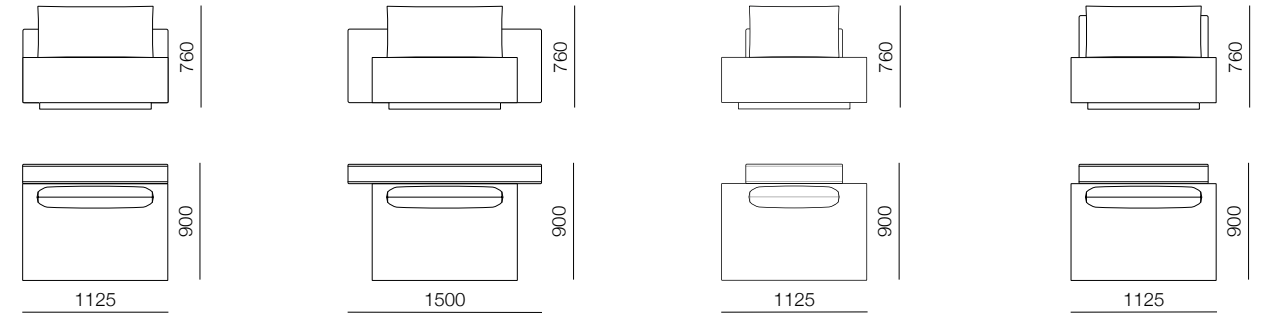

- 3.10**
S_1125
B_1125
C_900
- 3.11**
S_1125
B_1500
C_900
- 3.12**
S_1125
B_750
C_700
- 3.13**
S_1125 A_W750
B_1000 A_S750
C_900

_ OTTOMANS

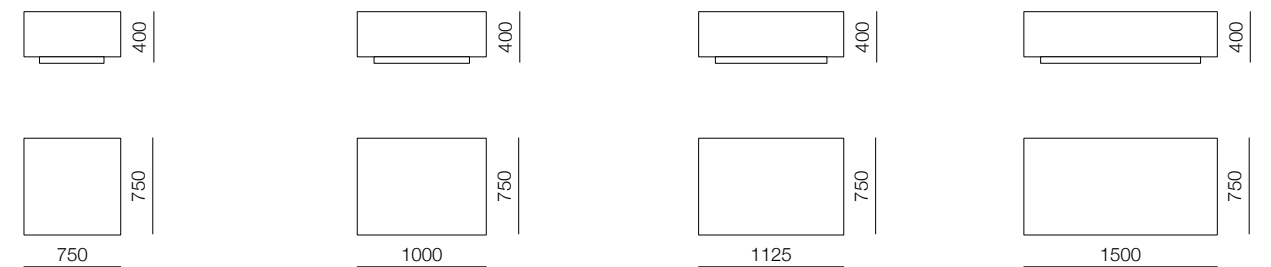

- O_750
- O_1000
- O_1125
- O_1500

_ COMPOSITIONS_2 SEAT

_750

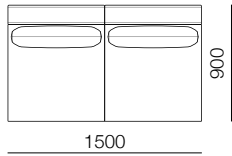
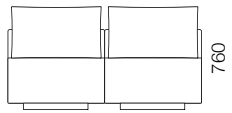

1.14
S_750
B_750
C_700

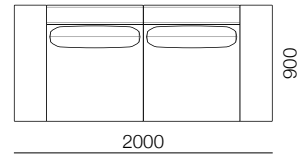
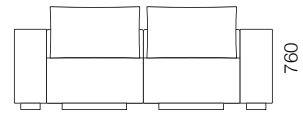

1.15
S_750 A_H900
B_750
C_700

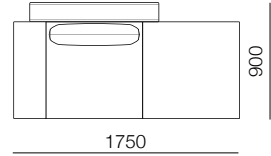
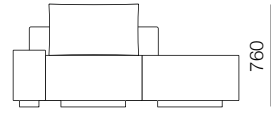

1.16
S_750 A_S900
B_1000
C_700

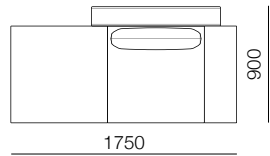
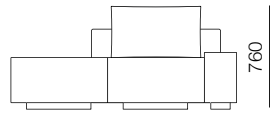

1.17
S_750 A_S900
B_1000
C_700

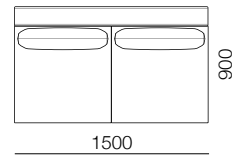
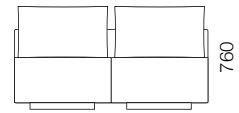

1.18
S_750
B_1500
C_700

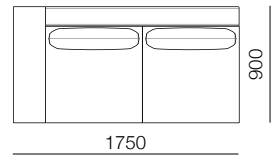
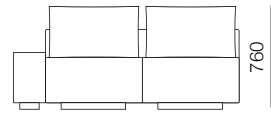

1.19
S_750 A_S900
B_1500
C_700

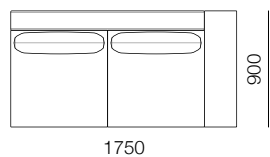
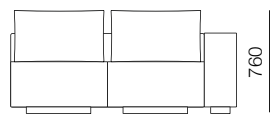

1.20
S_750 A_H900
B_1500
C_700

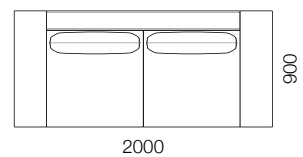
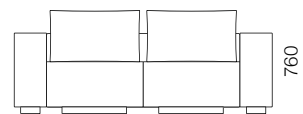

1.21
S_750 A_H900
B_1500
C_700

_ COMPOSITIONS_2 SEAT

_1000

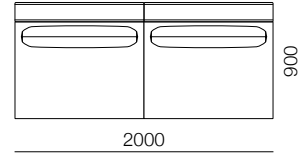
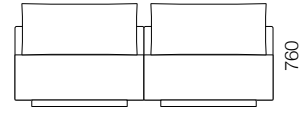

2.17
S_1000
B_1000
C_900

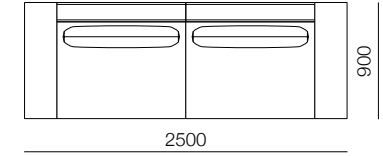
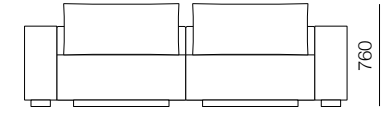

2.18
S_1000 A_H900
B_1000
C_900

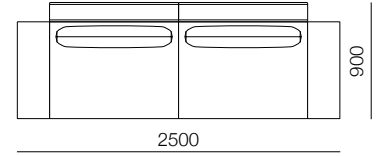
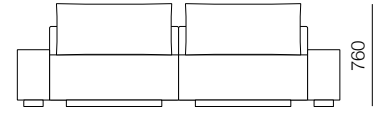

2.19
S_1000 A_S750
B_1000
C_900

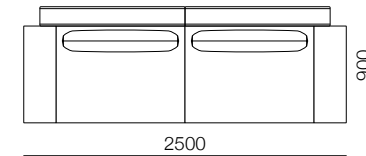
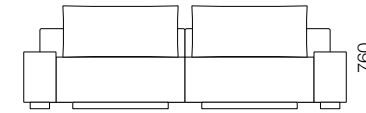

2.20
S_1000 A_S750
B_1125
C_900

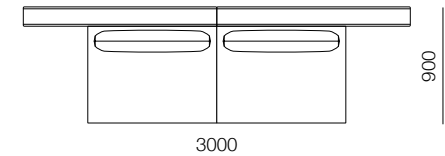
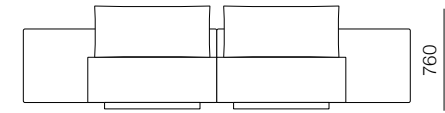

2.21
S_1000
B_1500
C_900

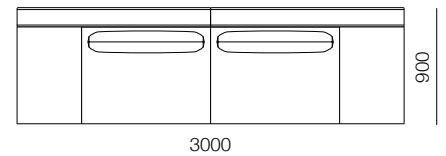
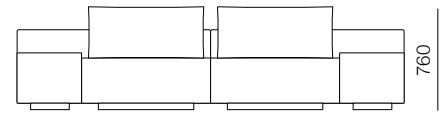

2.22
S_1000 A_W750
B_1500
C_900

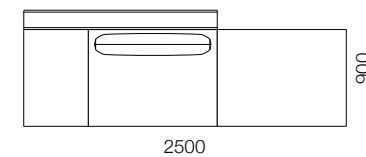
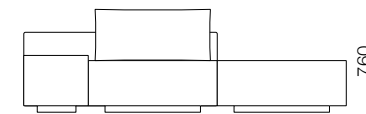

2.23
S_1000 A_W750
B_1500
C_900

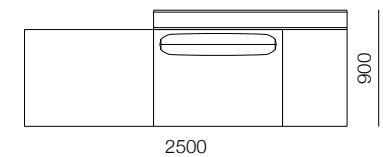
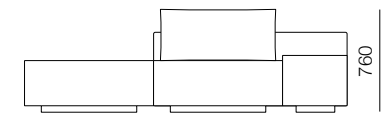

2.24
S_1000 A_W750
B_1500
C_900

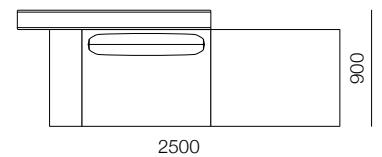
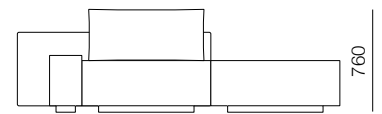

2.25
S_1000 A_S750
B_1500
C_900

_ COMPOSITIONS_2 SEAT

_1000

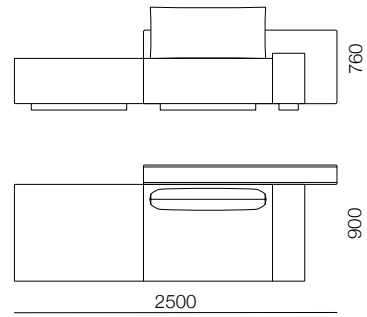

2.26
S_1000 A_S750
B_1500
C_900

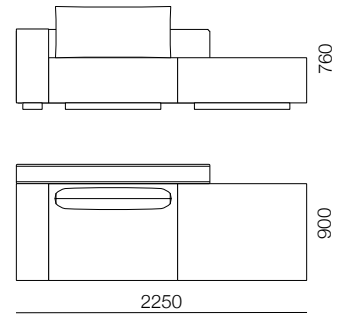

2.27
S_1000 A_H750
B_1500
C_900

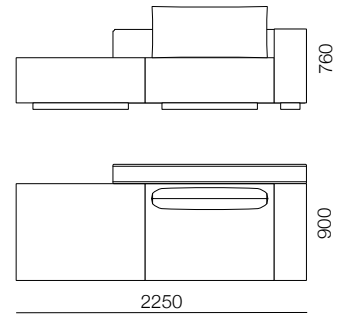

2.28
S_1000 A_H750
B_1500
C_900

_ COMPOSITIONS_2 SEAT

_1125

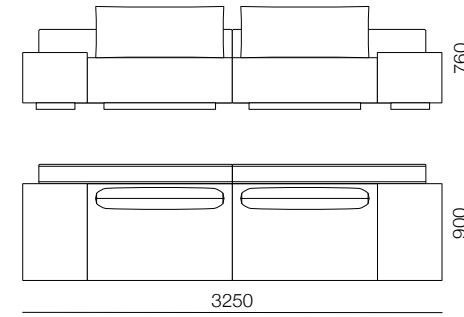

3.21
S_1125 A_W750
B_1500
C_1000

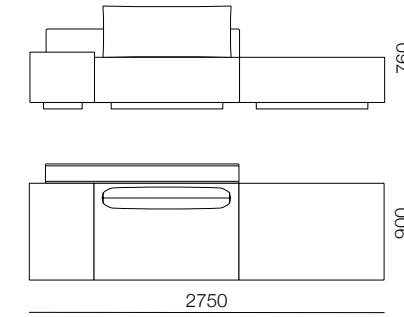

3.22
S_1125 A_W750
B_1500
C_1000

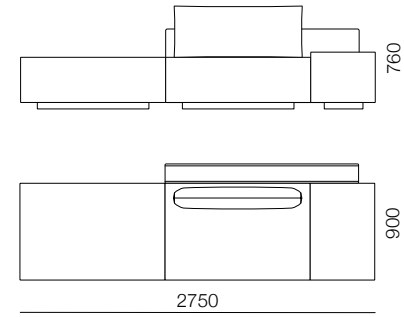

3.23
S_1125 A_W750
B_1500
C_1000

_1125

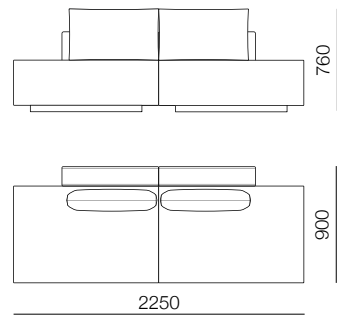

3.15
S_1125
B_750
C_700

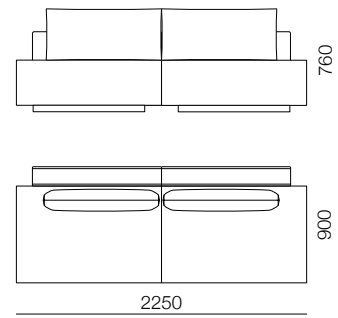

3.16
S_1125
B_1000
C_900

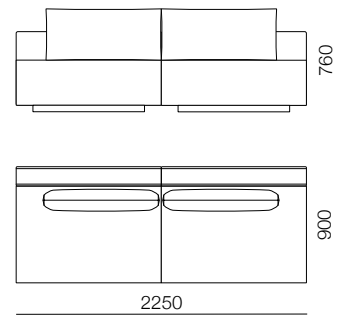

3.17
S_1125
B_1125
C_900

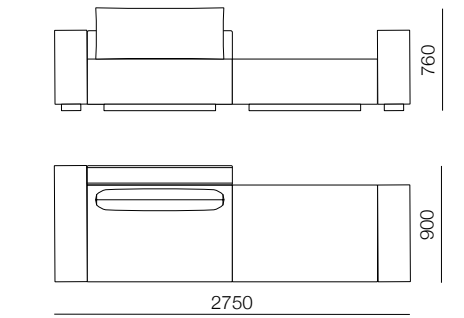

3.24
S_1125 A_H900
B_1125 A_H750
C_1000

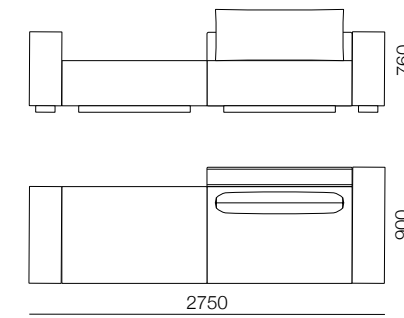

3.25
S_1125 A_H900
B_1125 A_H750
C_1000

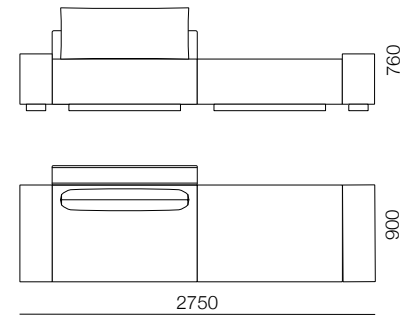

3.26
S_1125 A_S750
B_1125
C_1000

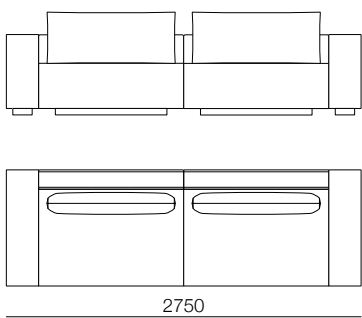

3.18
S_1125 A_H900
B_1125
C_1000

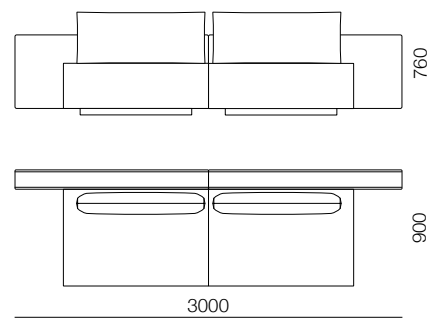

3.19
S_1125
B_1500
C_1000

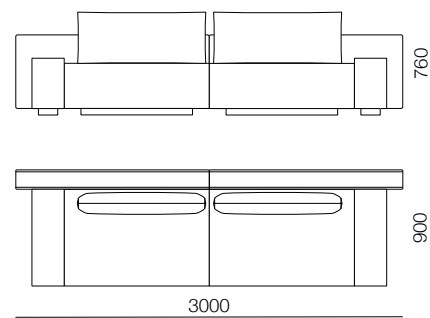

3.20
S_1125 A_S750
B_1500
C_1000

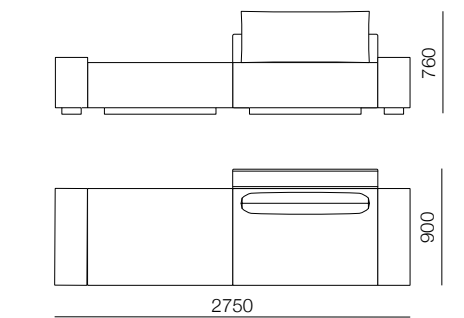

3.27
S_1125 A_S750
B_1125
C_1000

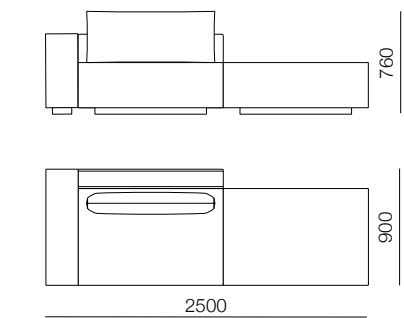

3.28
S_1125 A_H900
B_1125
C_1000

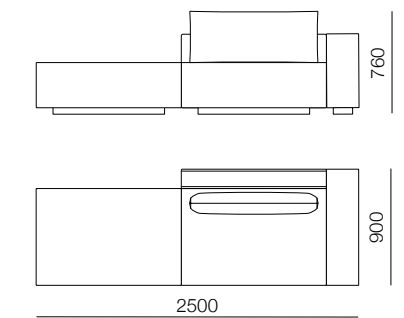

3.29
S_1125 A_H900
B_1125
C_1000

_ COMPOSITIONS_2 SEAT

_1500

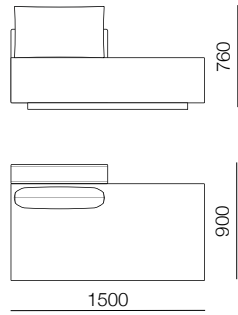

4.10
S_1500
B_750
C_700

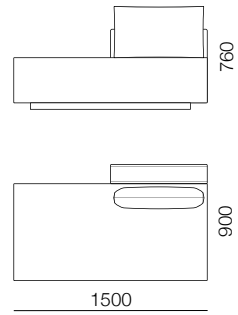

4.11
S_1500
B_750
C_700

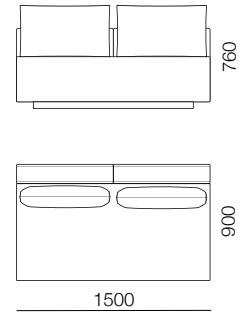

4.12
S_1500
B_750
C_700

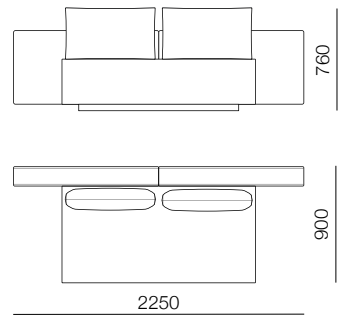

4.13
S_1500
B_1125
C_700

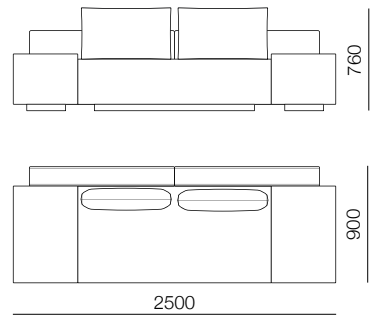

4.14
S_1500 A_W750
B_1125
C_700

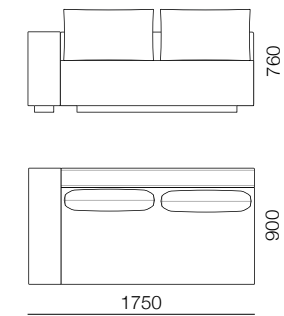

4.15
S_1500 A_H900
B_1500
C_700

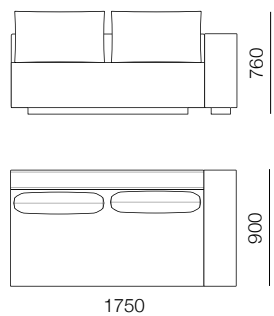

4.16
S_1500 A_H900
B_1500
C_700

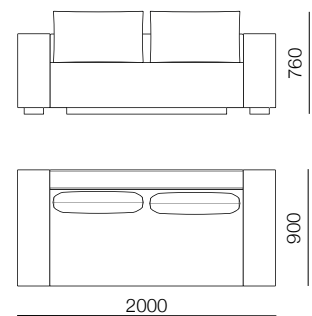

4.17
S_1500 A_H900
B_1500
C_700

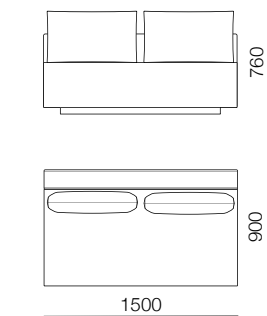

4.18
S_1500
B_1500
C_700

_ COMPOSITIONS_2 SEAT

_1500

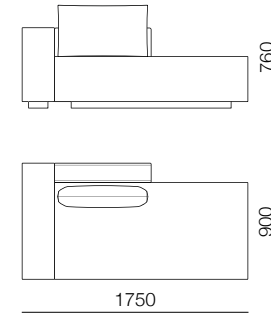

4.19
S_1500 A_H900
B_750
C_700

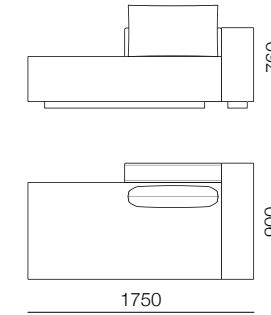

4.20
S_1500 A_H900
B_750
C_700

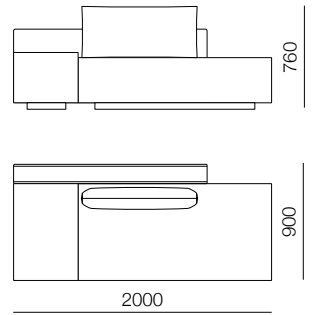

4.21
S_1500 A_W750
B_1500
C_900

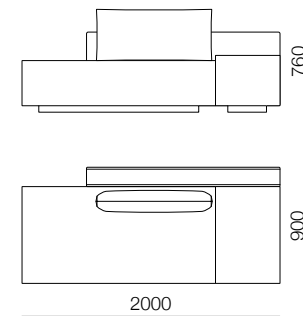

4.22
S_1500 A_W750
B_1500
C_900

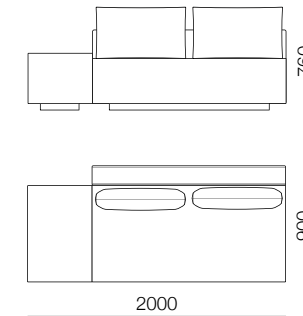

4.23
S_1500 A_W750
B_1500
C_700

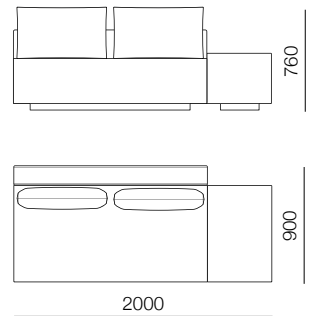

4.24
S_1500 A_W750
B_1500
C_700

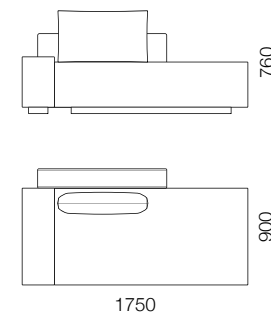

4.25
S_1500 A_S750
B_1000
C_700

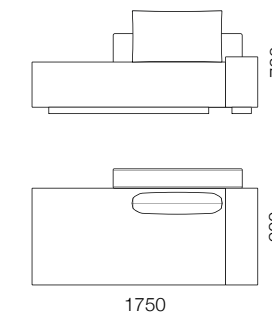

4.26
S_1500 A_S750
B_1000
C_700

_ COMPOSITIONS_3 SEAT

_750

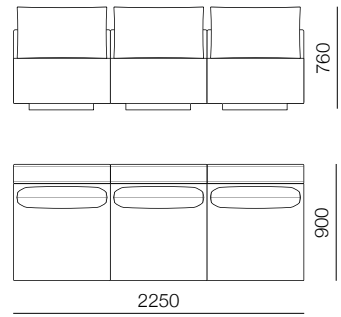

1.22
S_750
B_750
C_700

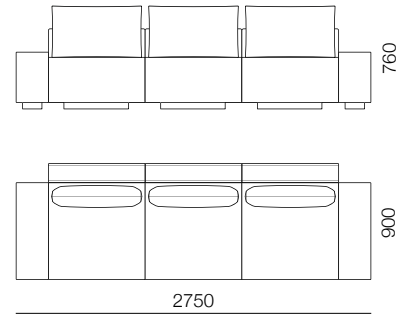

1.23
S_750 A_S750
B_750
C_700

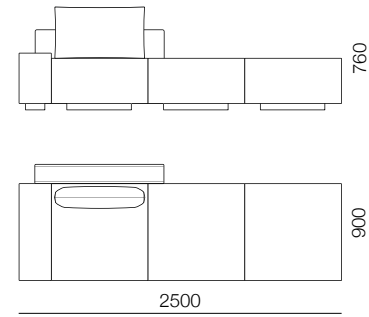

1.24
S_750 A_S750
B_1000
C_700

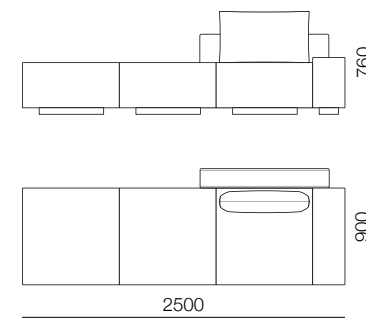

1.25
S_750 A_S750
B_1000
C_700

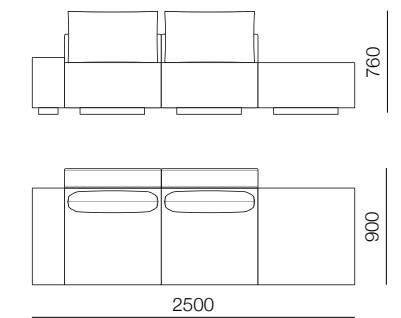

1.26
S_750 A_S750
B_750
C_700

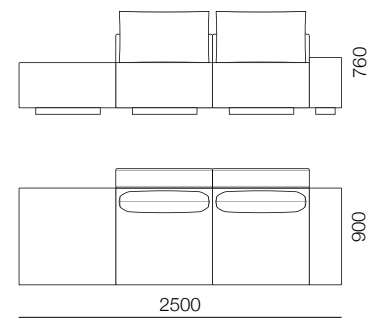

1.27
S_750 A_S750
B_750
C_700

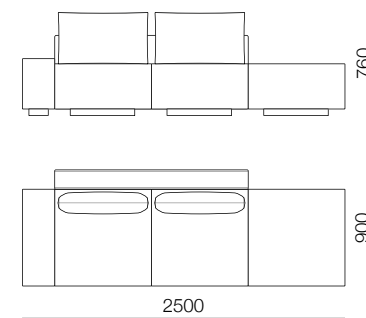

1.28
S_750 A_S750
B_1500
C_700

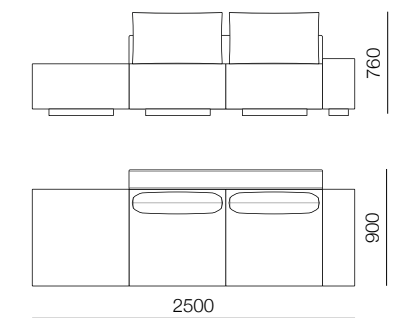

1.29
S_750 A_S750
B_1500
C_700

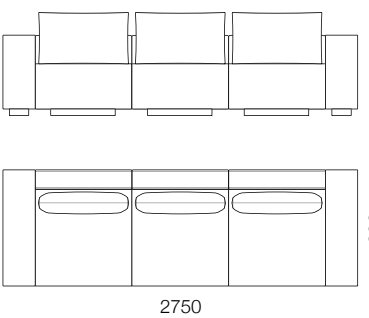

1.30
S_750 A_H900
B_750
C_700

_ COMPOSITIONS_3 SEAT

_750

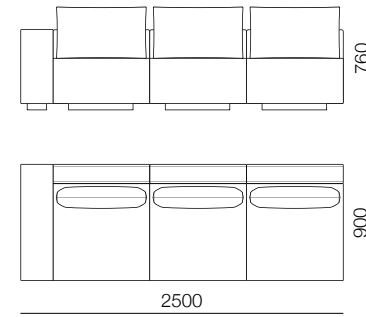

1.31
S_750 A_H900
B_750
C_700

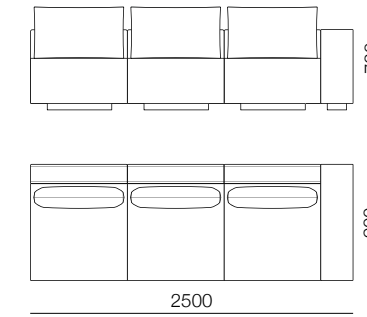

1.32
S_750 A_H900
B_750
C_700

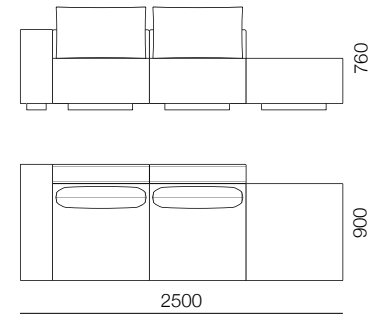

1.33
S_750 A_H900
B_750
C_700

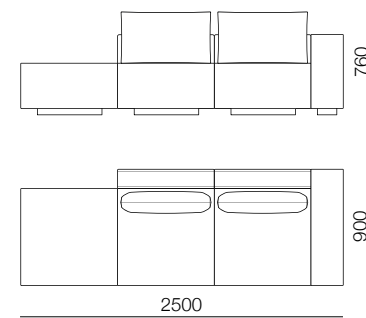

1.34
S_750 A_H900
B_750
C_700

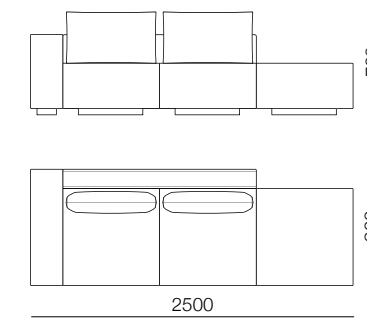

1.35
S_750 A_H900
B_1500
C_700

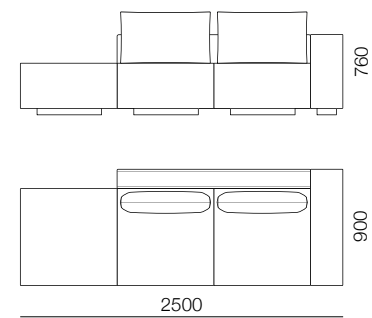

1.36
S_750 A_H900
B_1500
C_700

_ COMPOSITIONS_3 SEAT

_1000

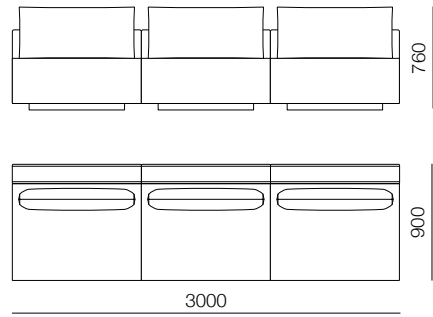

2.29
S_1000
B_1000
C_900

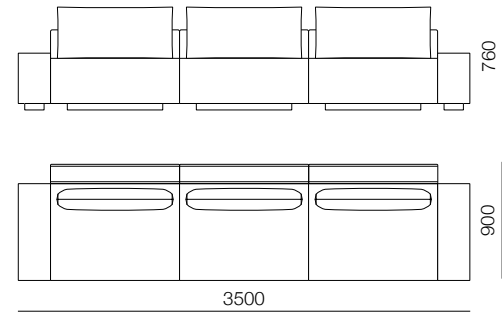

2.30
S_1000 A_S750
B_1000
C_900

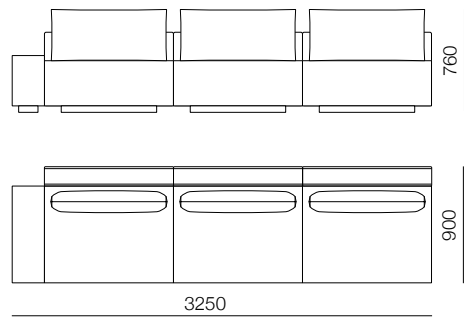

2.31
S_1000 A_S750
B_1000
C_900

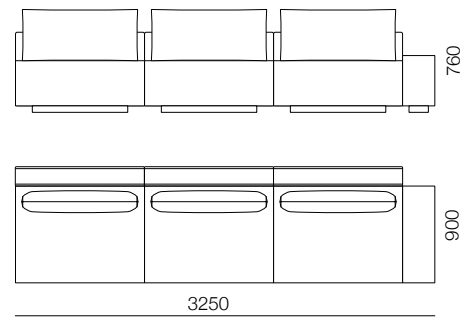

2.32
S_1000 A_S750
B_1000
C_900

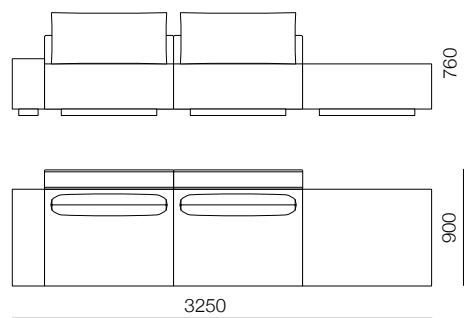

2.33
S_1000 A_S750
B_1000
C_900

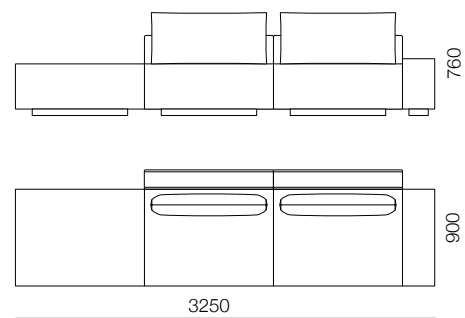

2.34
S_1000 A_S750
B_1000
C_900

_ COMPOSITIONS_3 SEAT

_1000

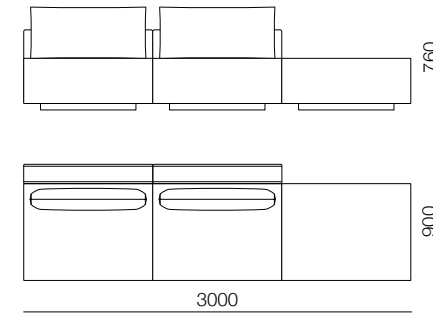

2.35
S_1000
B_1000
C_900

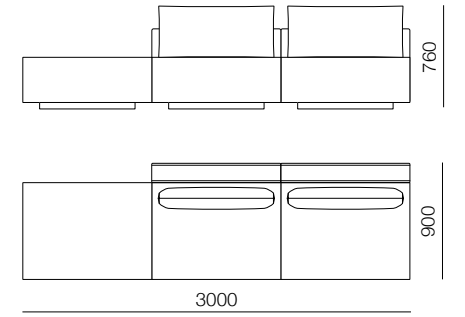

2.36
S_1000
B_1000
C_900

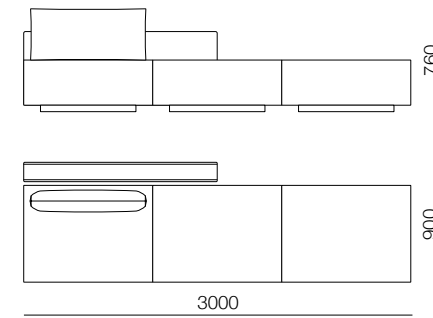

2.37
S_1000
B_1500
C_900

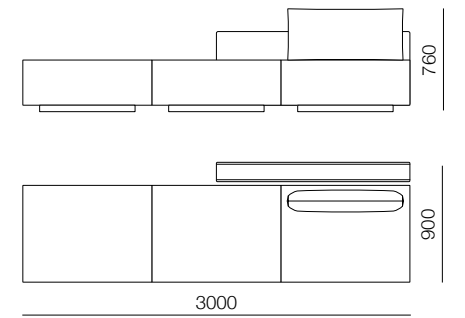

2.38
S_1000
B_1500
C_900

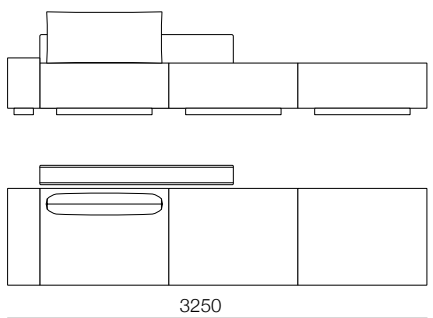

2.39
S_1000 A_S750
B_1500
C_900

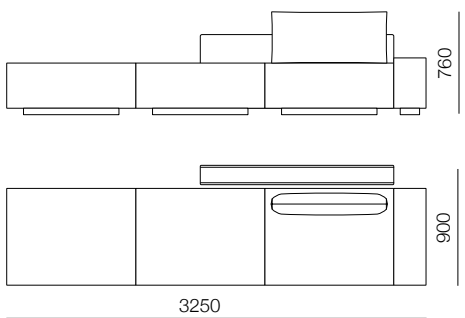

2.40
S_1000 A_S750
B_1500
C_900

_ COMPOSITIONS_3 SEAT

_1000

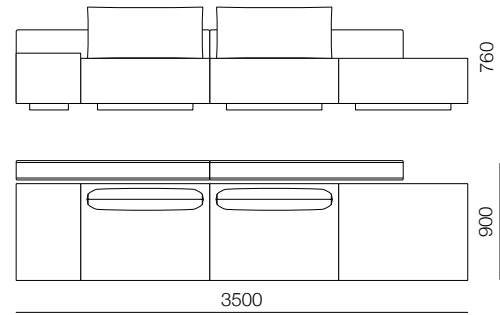

2.41
S_1000 A_W750
B_1500
C_900

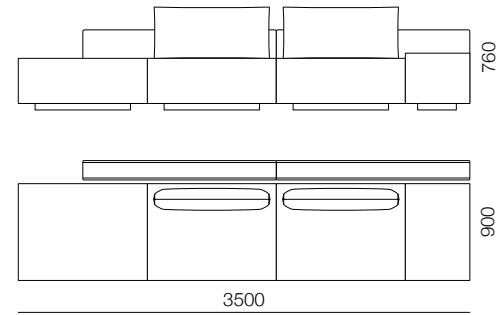

2.42
S_1000 A_W750
B_1500
C_900

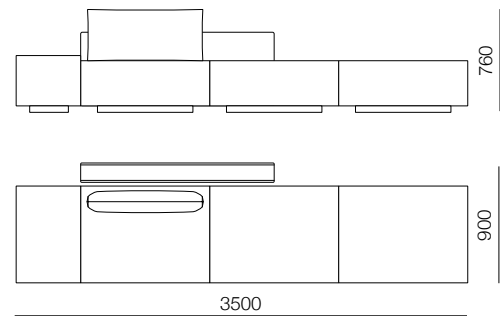

2.43
S_1000 A_W750
B_1500
C_900

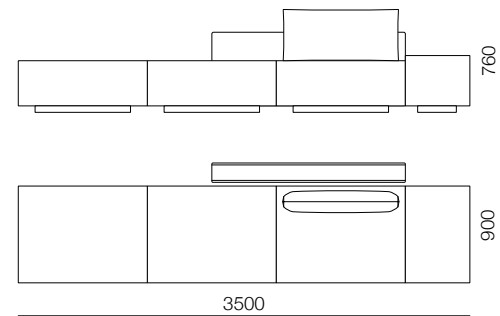

2.44
S_1000 A_W750
B_1500
C_900

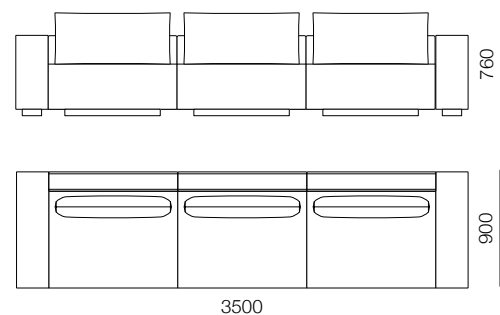

2.45
S_1000 A_H900
B_1000
C_900

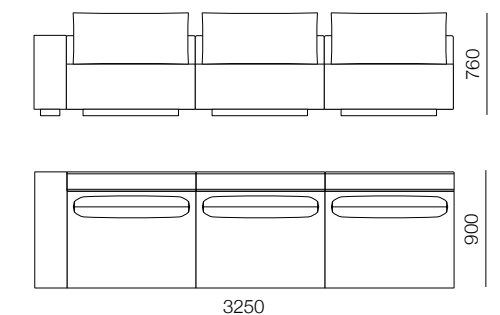

2.46
S_1000 A_H900
B_1000
C_900

_ COMPOSITIONS_3 SEAT

_1000

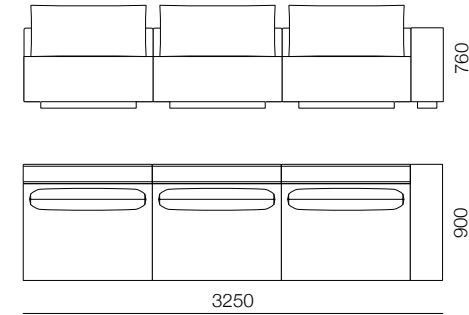

2.47
S_1000 A_H900
B_1000
C_900

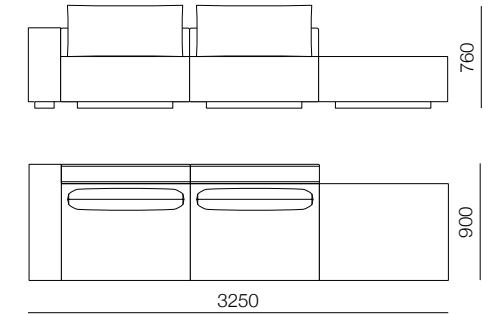

2.48
S_1000 A_H900
B_1000
C_900

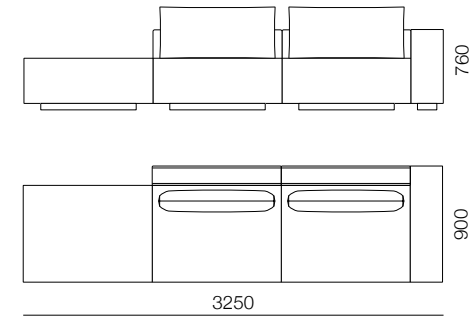

2.49
S_1000 A_H900
B_1000
C_900

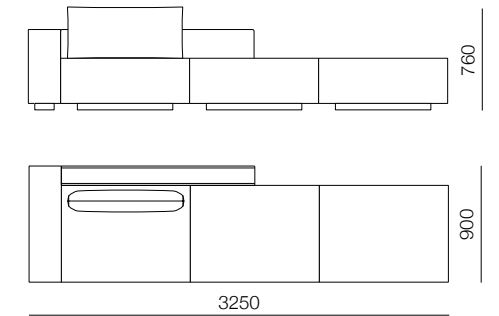

2.50
S_1000 A_H900
B_1500
C_900

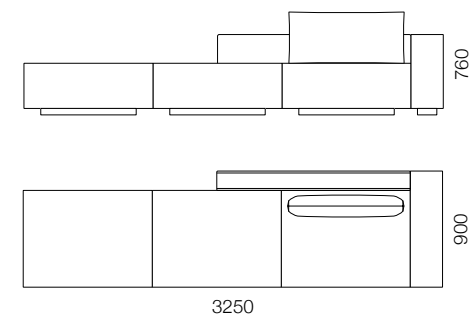

2.51
S_1000 A_H900
B_1500
C_900

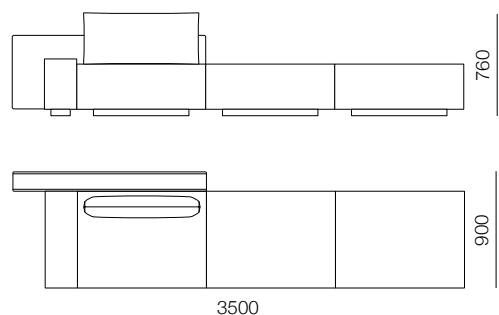

2.52
S_1000 A_S750
B_1500
C_900

_ COMPOSITIONS_3 SEAT

_1125

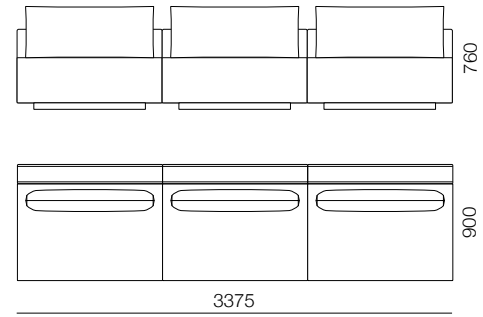

3.30
S_1125
B_1125
C_1000

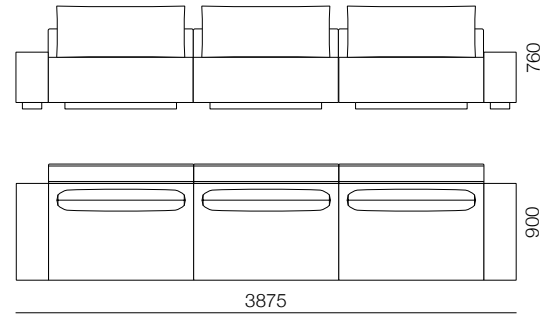

3.31
S_1125 A_S750
B_1125
C_1000

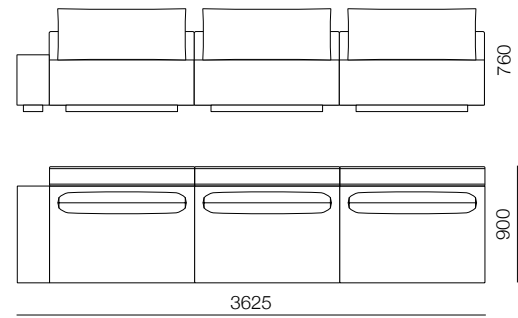

3.32
S_1125 A_S750
B_1125
C_1000

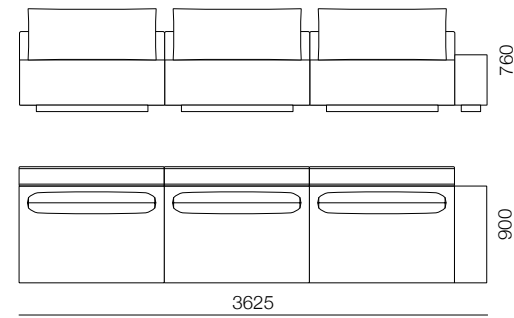

3.33
S_1125 A_S750
B_1125
C_1000

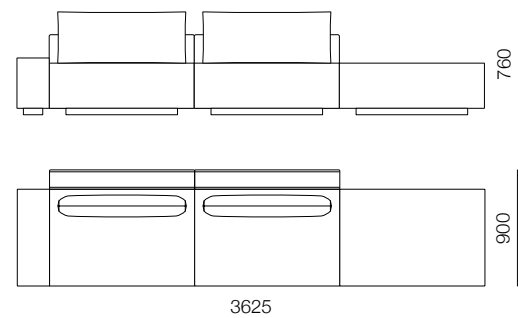

3.34
S_1125 A_S750
B_1125
C_1000

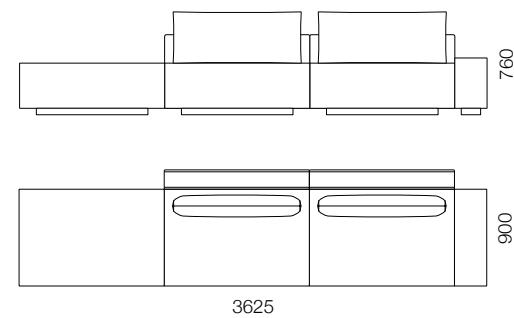

3.35
S_1125 A_S750
B_1125
C_1000

_ COMPOSITIONS_3 SEAT

_1125

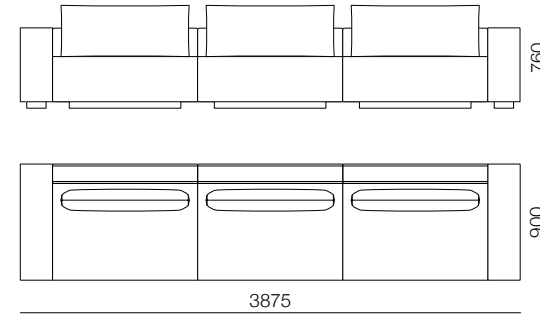

3.36
S_1125 A_H900
B_1125
C_1000

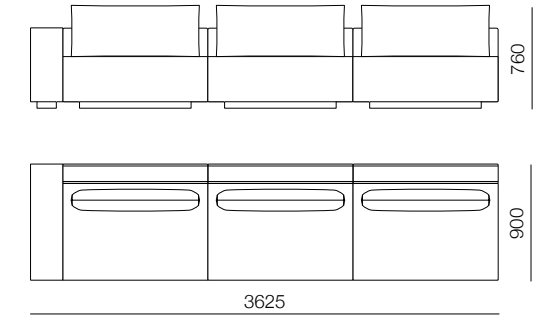

3.37
S_1125 A_H900
B_1125
C_1000

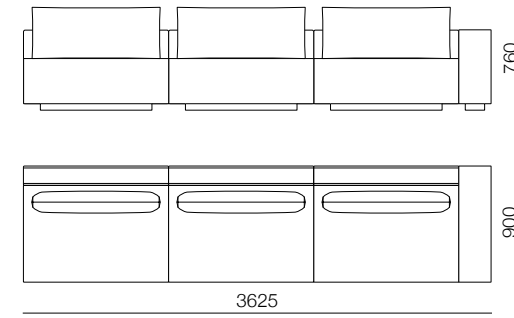

3.38
S_1125 A_H900
B_1125
C_1000

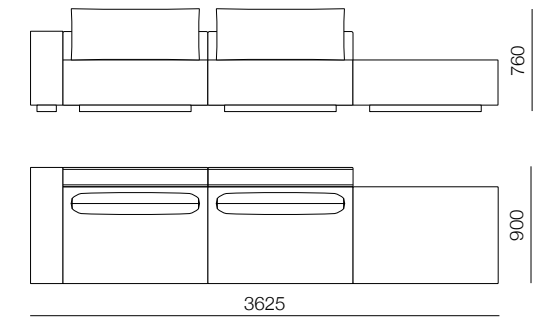

3.39
S_1125 A_H900
B_1125
C_1000

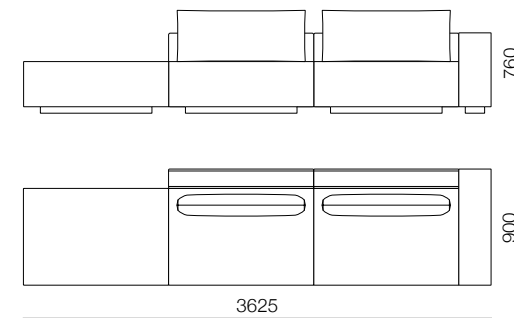

3.40
S_1125 A_H900
B_1125
C_1000

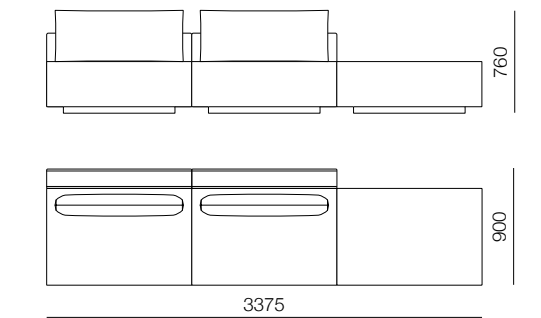

3.41
S_1125
B_1125
C_1000

_ COMPOSITIONS_3 SEAT

_1125

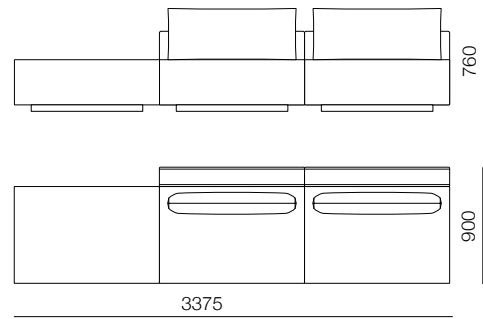

3.42
S_1125
B_1125
C_1000

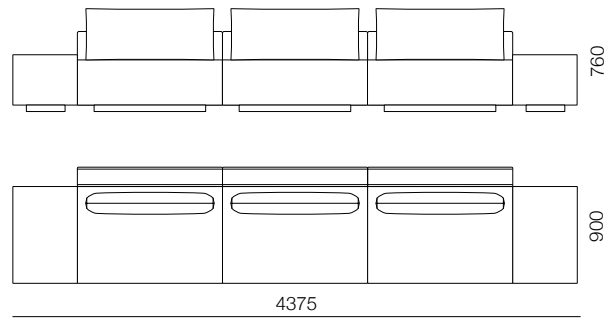

3.43
S_1125 A_W750
B_1125
C_1000

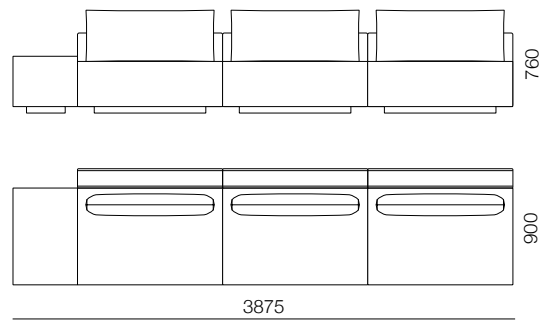

3.44
S_1125 A_W750
B_1125
C_1000

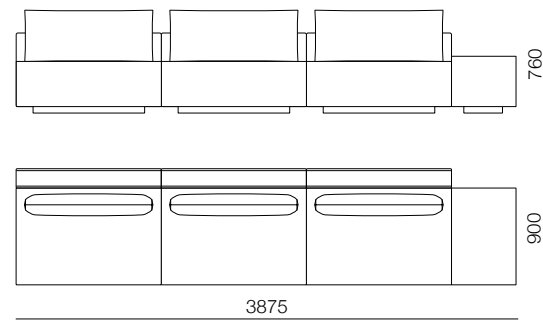

3.45
S_1125 A_W750
B_1125
C_1000

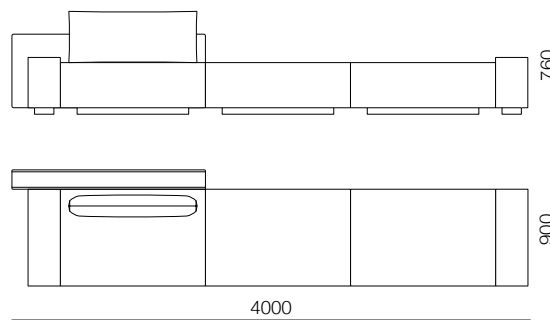

3.46
S_1125 A_S750
B_1500
C_1000

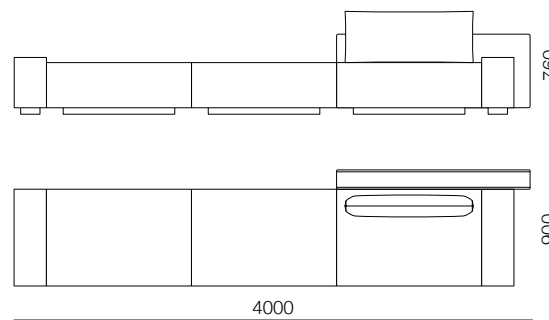

3.47
S_1125 A_S750
B_1500
C_1000

_ COMPOSITIONS_3 SEAT

_1125

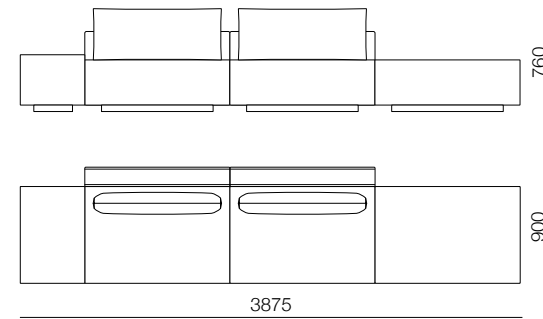

3.48
S_1125 A_W750
B_1125
C_1000

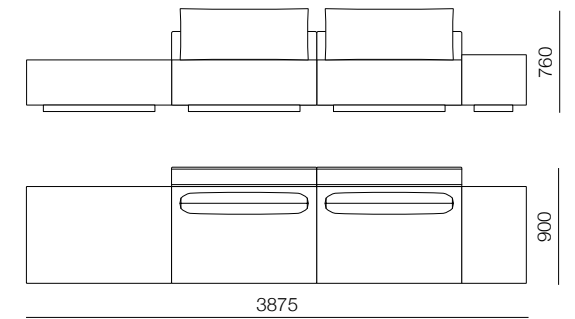

3.49
S_1125 A_W750
B_1125
C_1000

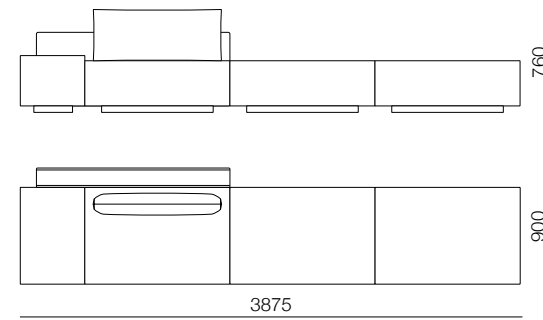

3.50
S_1125 A_W750
B_1500
C_1000

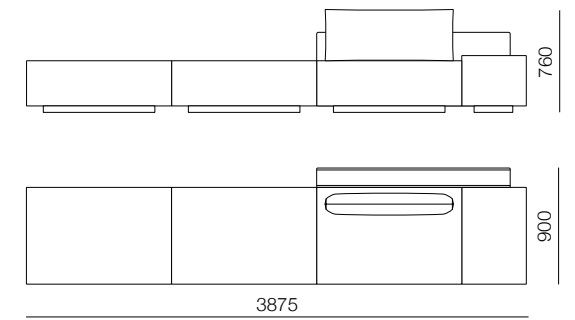

3.51
S_1125 A_W750
B_1500
C_1000

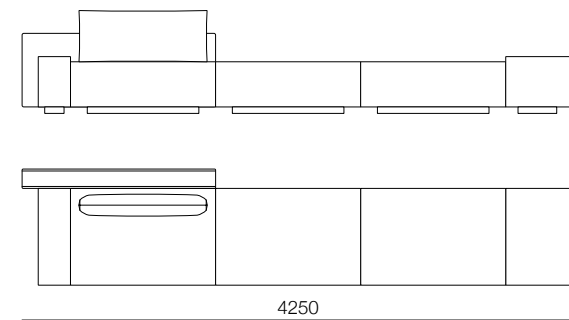

3.52
S_1125 A_S750
B_1500 A_W750
C_1000

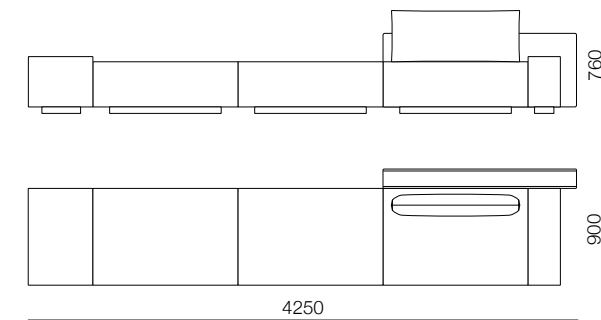

3.53
S_1125 A_S750
B_1500 A_W750
C_1000

_ COMPOSITIONS_4 SEAT

_750

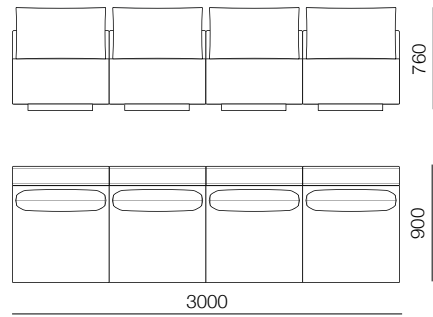

1.37
S_750
B_750
C_700

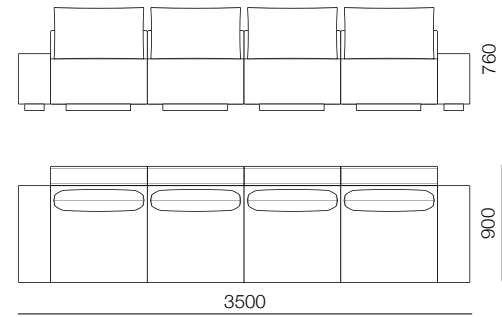

1.38
S_750 A_S750
B_750
C_700

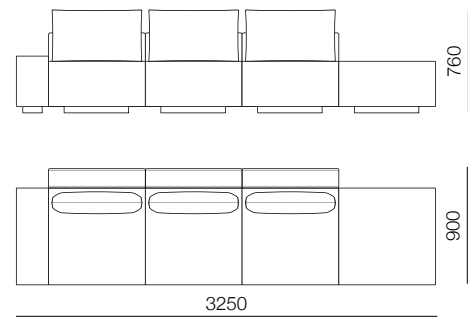

1.39
S_750 A_S750
B_750
C_700

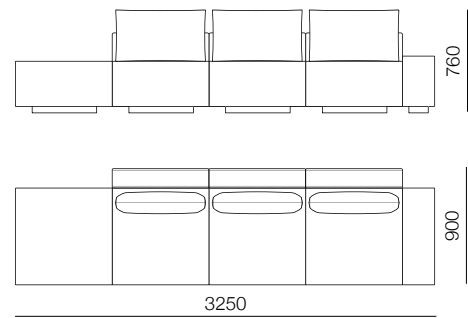

1.40
S_750 A_S750
B_750
C_700

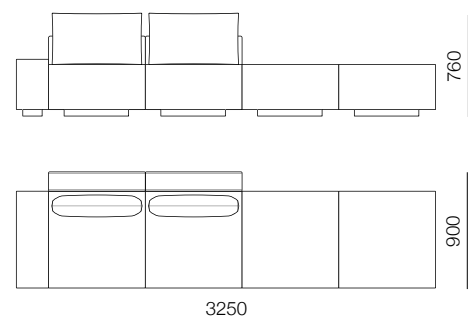

1.41
S_750 A_S750
B_750
C_700

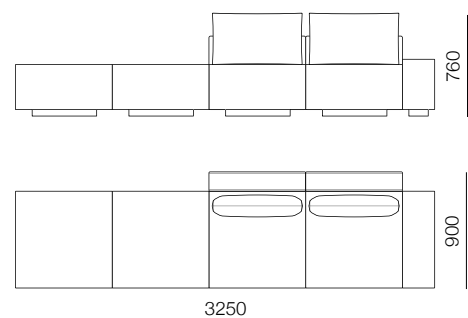

1.42
S_750 A_S750
B_750
C_700

_ COMPOSITIONS_4 SEAT

_750

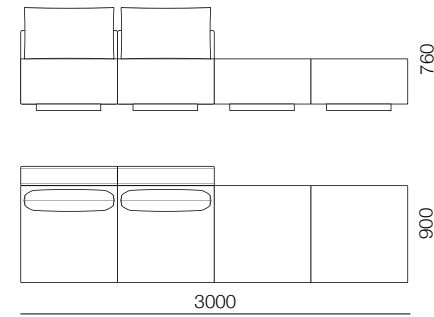

1.43
S_750
B_750
C_700

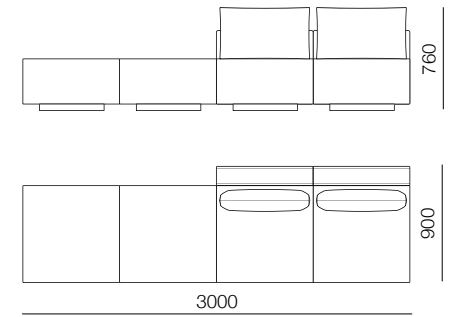

1.44
S_750
B_750
C_700

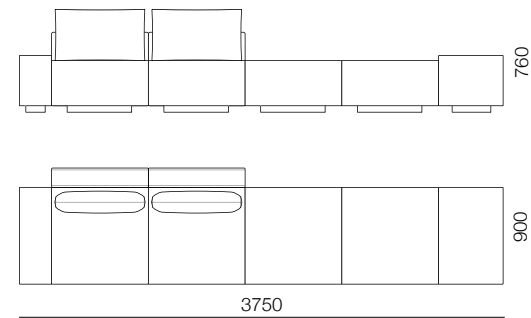

1.45
S_750 A_S750
B_750 A_W750
C_700

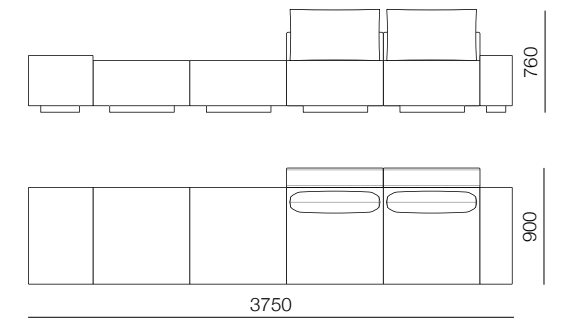

1.46
S_750 A_S750
B_750 A_W750
C_700

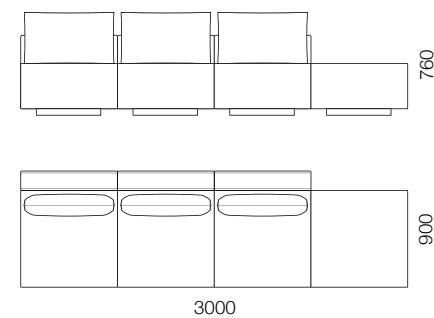

1.47
S_750
B_750
C_700

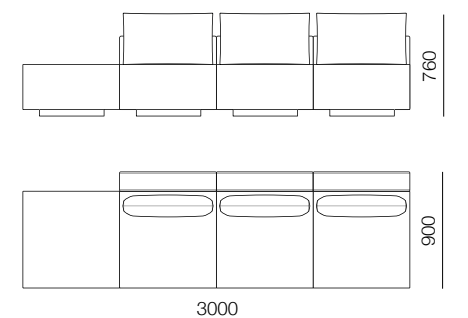

1.48
S_750
B_750
C_700

_ COMPOSITIONS_4 SEAT

_750

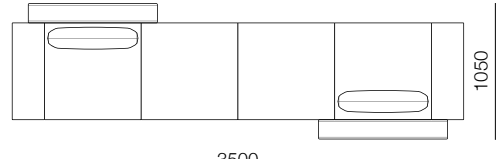
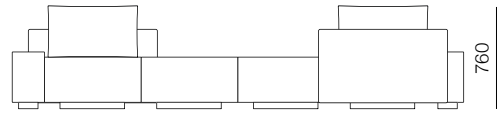

1.49

S_750 A_S750
B_1000
C_700

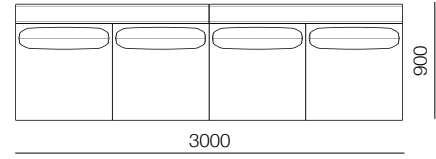
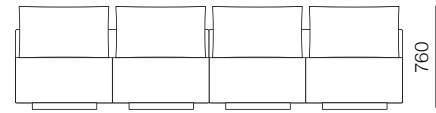

1.50

S_750
B_1500
C_700

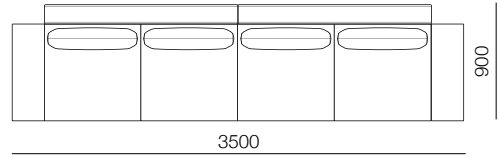
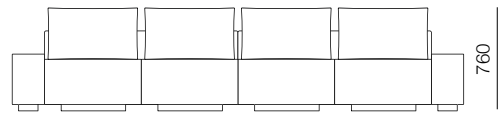

1.51

S_750 A_S750
B_1500
C_700

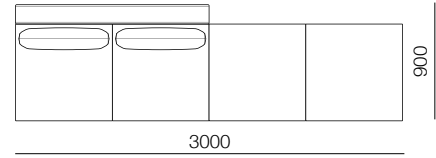
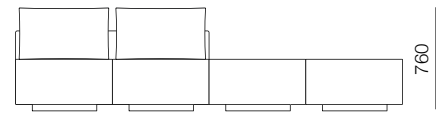

1.52

S_750
B_1500
C_700

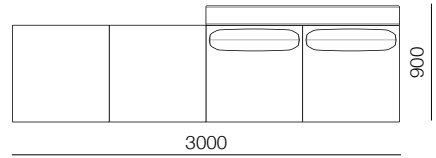
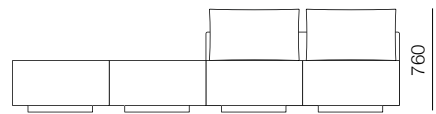

1.53

S_750
B_1500
C_700

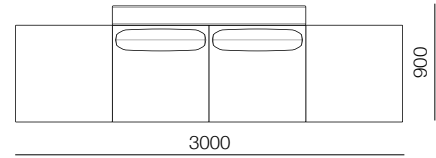
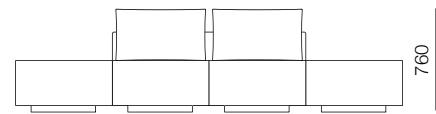

1.54

S_750
B_1500
C_700

_ COMPOSITIONS_4 SEAT

_750

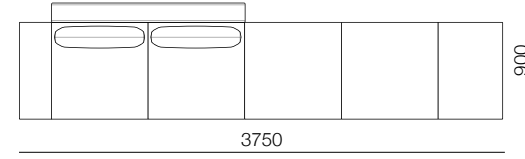
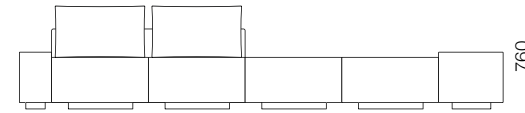

1.55

S_750 A_W750
B_1500 A_S750
C_700

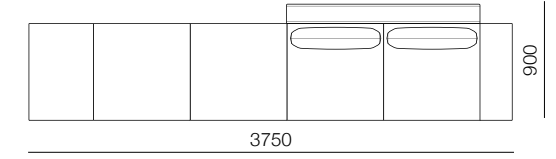
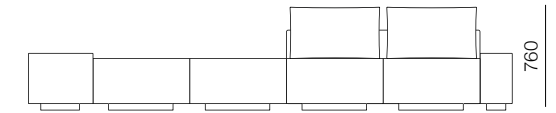

1.56

S_750 A_W750
B_1500 A_S750
C_700

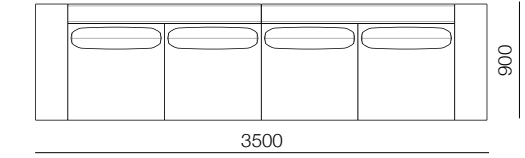
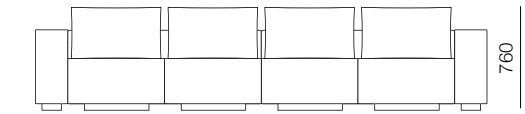

1.57

S_750 A_H900
B_1500
C_700

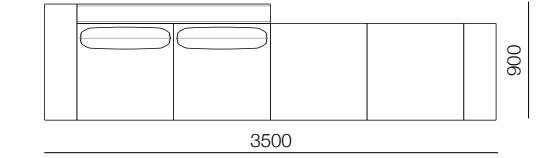
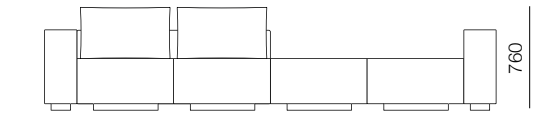

1.58

S_750 A_H750
B_1500 A_H900
C_700

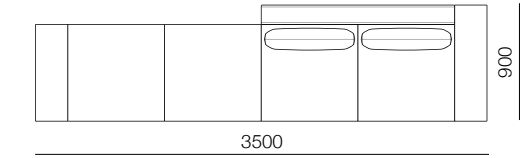
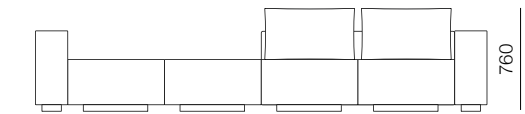

1.59

S_750 A_H750
B_1500 A_H900
C_700

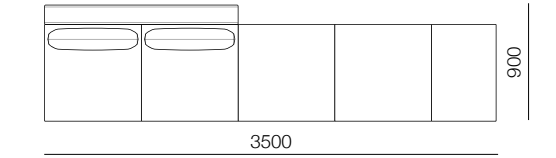
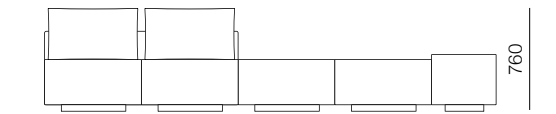

1.60

S_750 A_W750
B_1500
C_700

_ COMPOSITIONS_4 SEAT

_1000

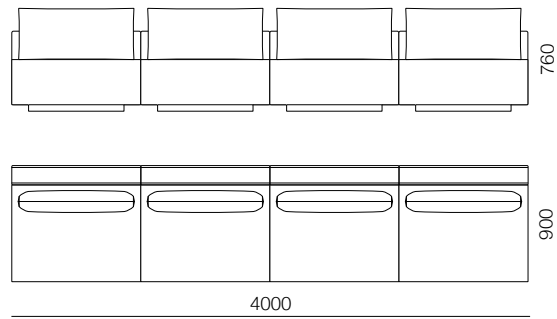

2.52
S_1000
B_1000
C_900

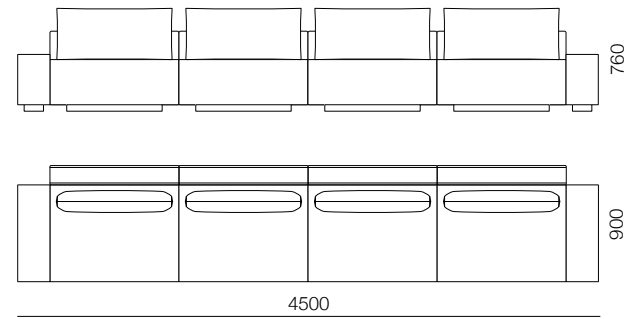

2.53
S_1000 A_S750
B_1000
C_900

_ COMPOSITIONS_4 SEAT

_1000

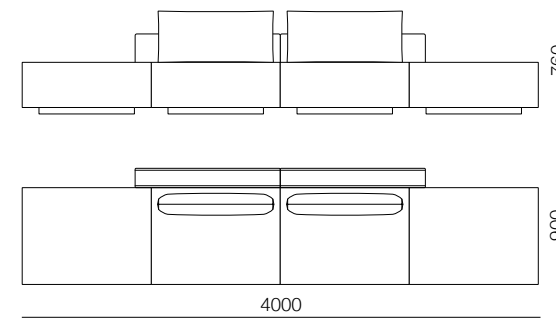

2.58
S_1000
B_1125
C_900

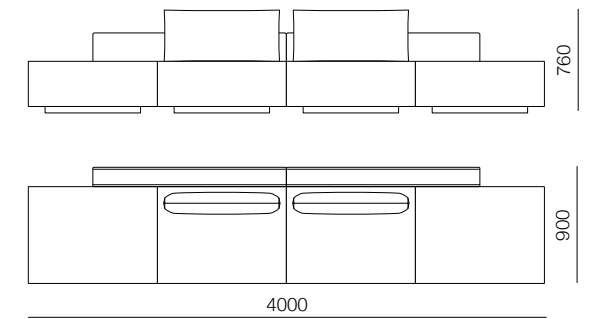

2.59
S_1000
B_1500
C_900

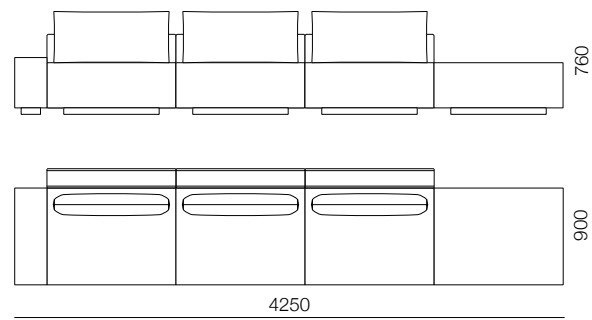

2.54
S_1000 A_S750
B_1000
C_900

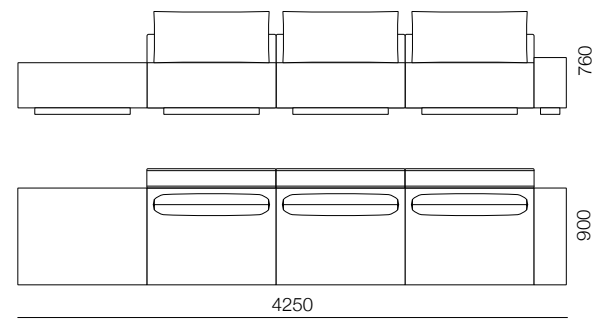

2.55
S_1000 A_S750
B_1000
C_900

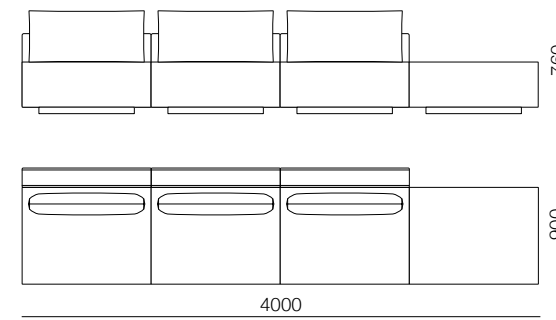

2.60
S_1000
B_1000
C_900

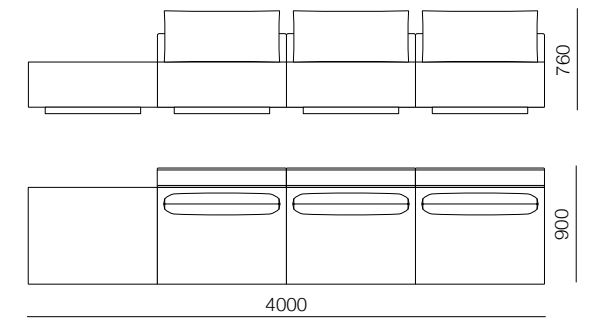

2.61
S_1000
B_1000
C_900

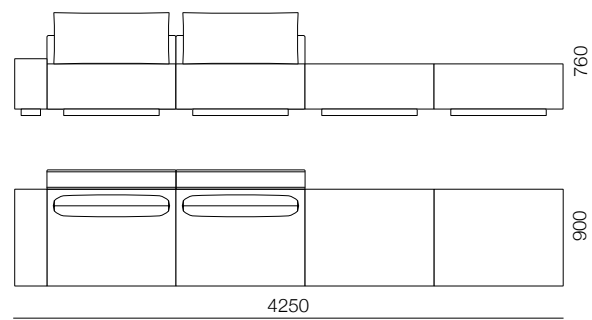

2.56
S_1000 A_S750
B_1000
C_900

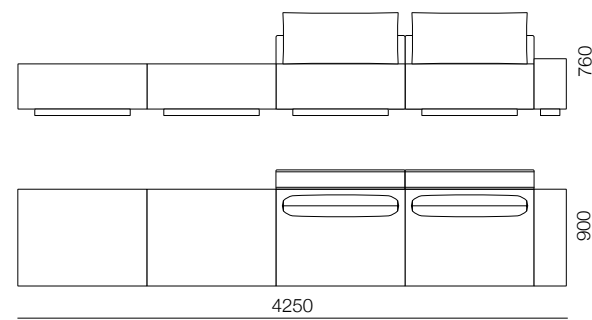

2.57
S_1000 A_S750
B_1000
C_900

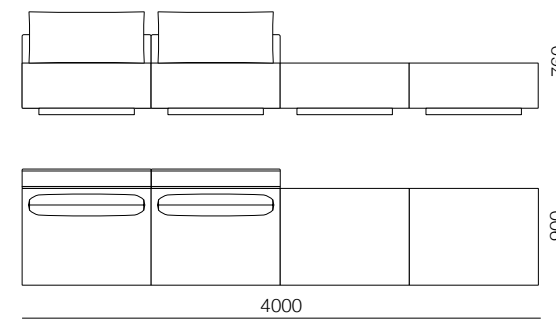

2.62
S_1000
B_1000
C_900

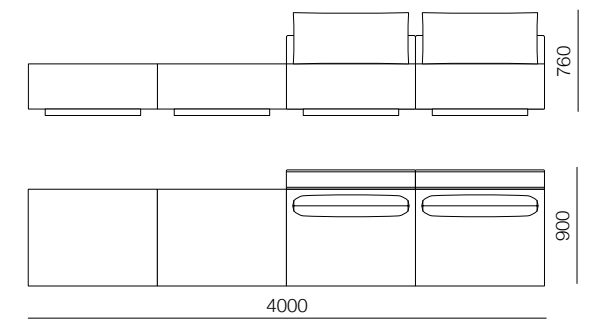

2.63
S_1000
B_1000
C_900

_ COMPOSITIONS_4 SEAT

_1000

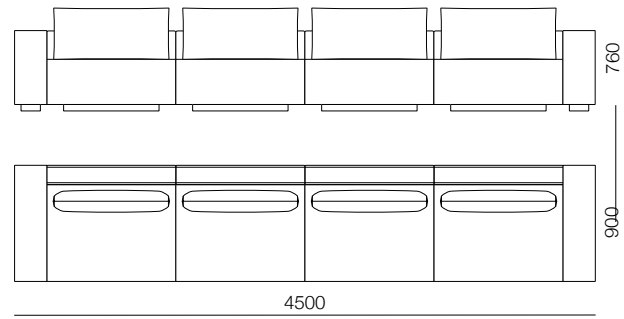

2.64
S_1000 A_H900
B_1000
C_900

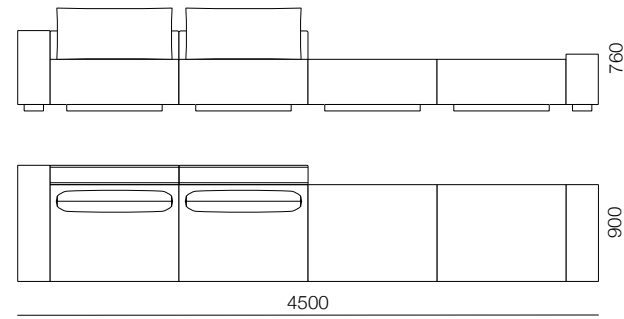

2.65
S_1000 A_H900
B_1000 A_S750
C_900

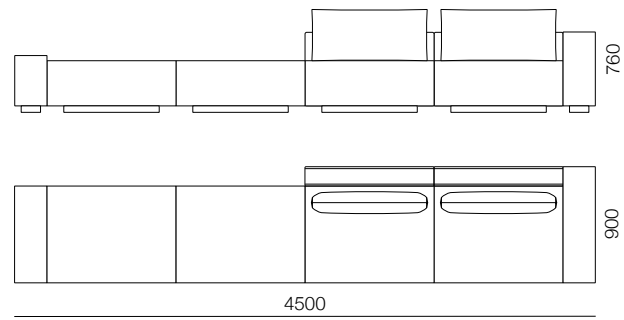

2.66
S_1000 A_H900
B_1000 A_S750
C_900

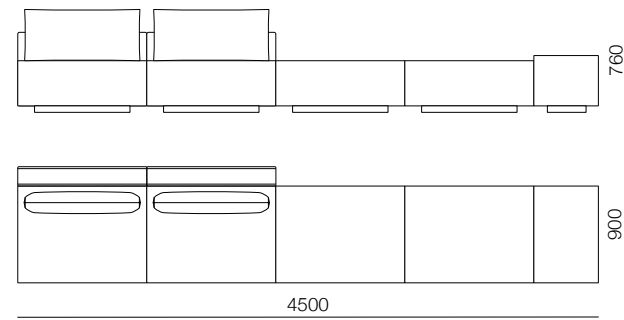

2.67
S_1000 A_W750
B_1000
C_900

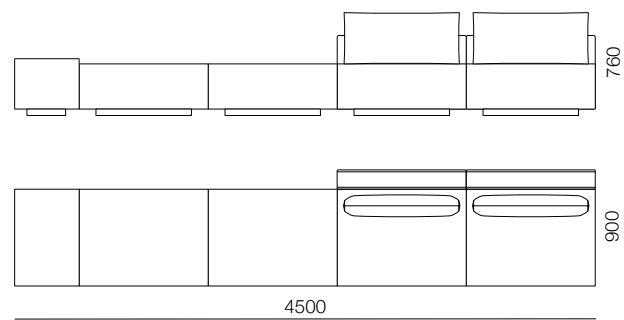

2.68
S_1000 A_W750
B_1000
C_900

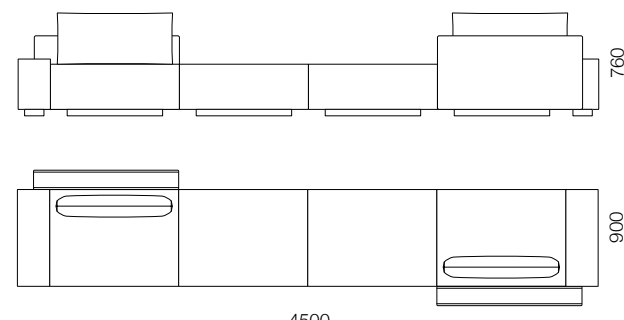

2.69
S_1000 A_S750
B_1125
C_900

_ COMPOSITIONS_4 SEAT

_1000

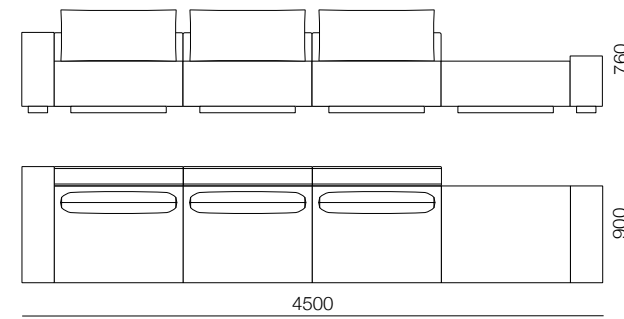

2.70
S_1000 A_H900
B_1000 A_S750
C_900

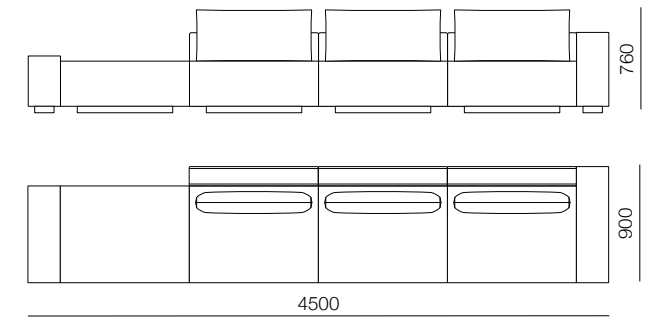

2.71
S_1000 A_H900
B_1000 A_S750
C_900

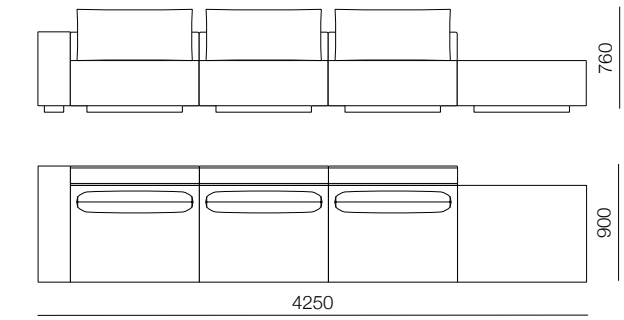

2.72
S_1000 A_H900
B_1000
C_900

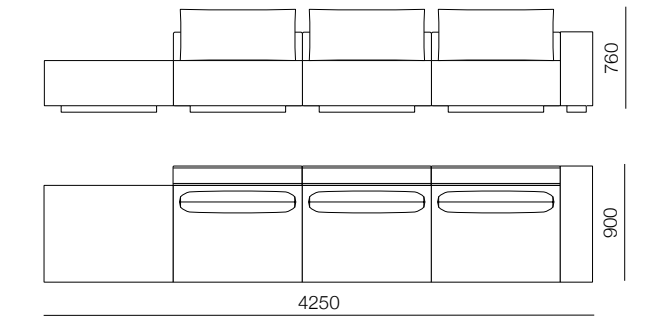

2.73
S_1000 A_H900
B_1000
C_900

_ COMPOSITIONS_4 SEAT

_1125

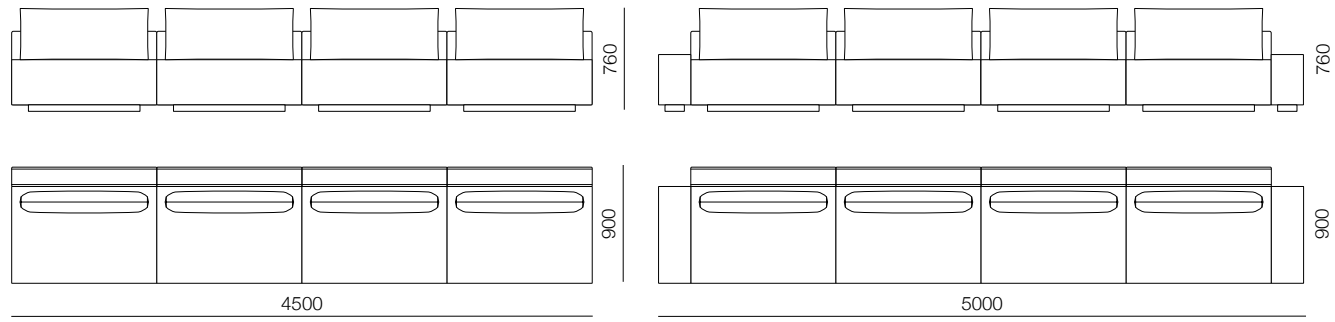

3.54
S_1125
B_1125
C_1000

3.55
S_1125 A_S750
B_1125
C_1000

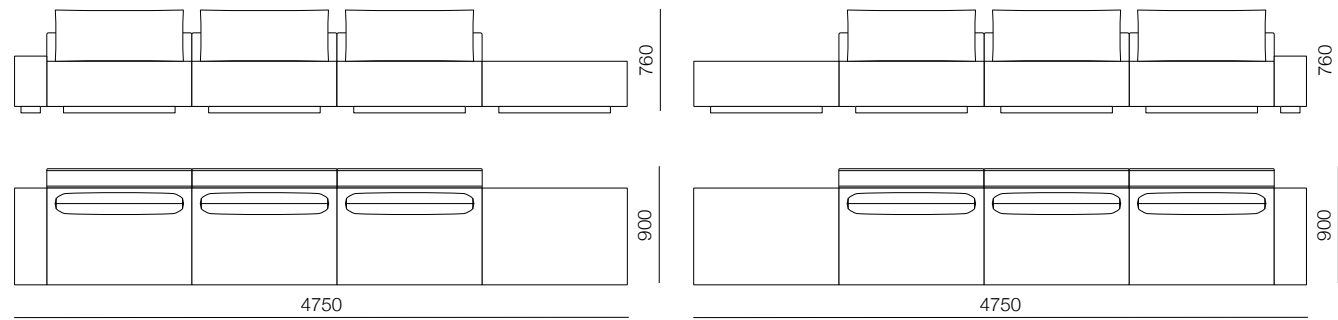

3.56
S_1125 A_S750
B_1125
C_1000

3.57
S_1125 A_S750
B_1125
C_1000

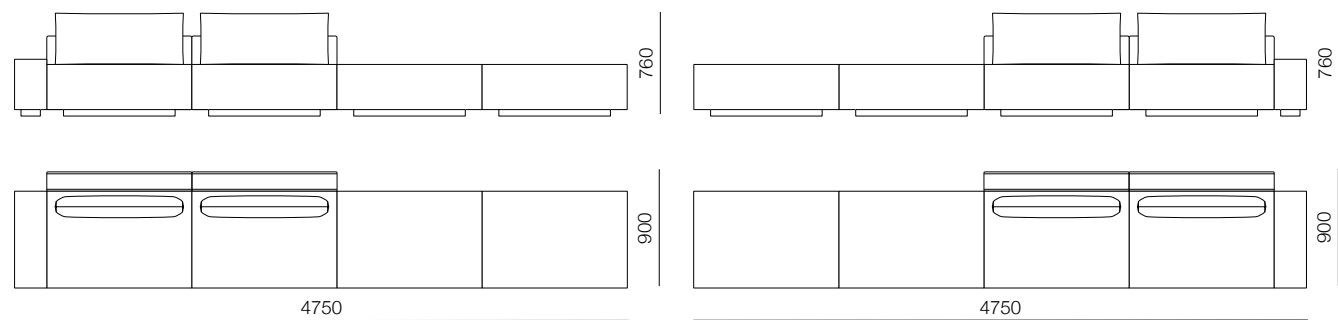

3.58
S_1125 A_S750
B_1125
C_1000

3.59
S_1125 A_S750
B_1125
C_1000

_ COMPOSITIONS_4 SEAT

_1125

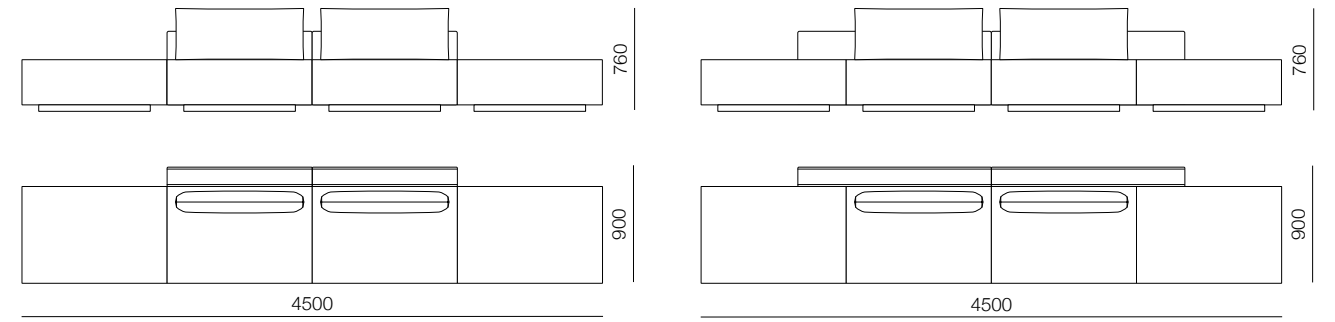

3.60
S_1125
B_1125
C_1000

3.61
S_1125
B_1500
C_1000

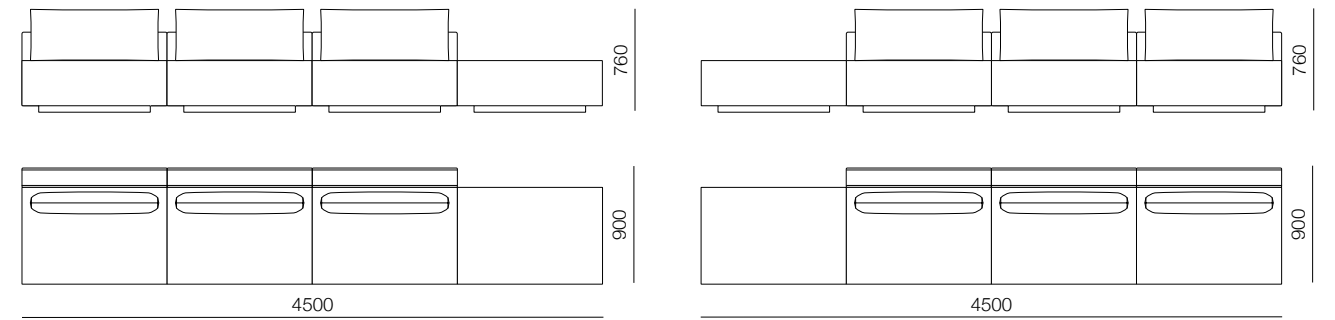

3.62
S_1125
B_1125
C_1000

3.63
S_1125
B_1125
C_1000

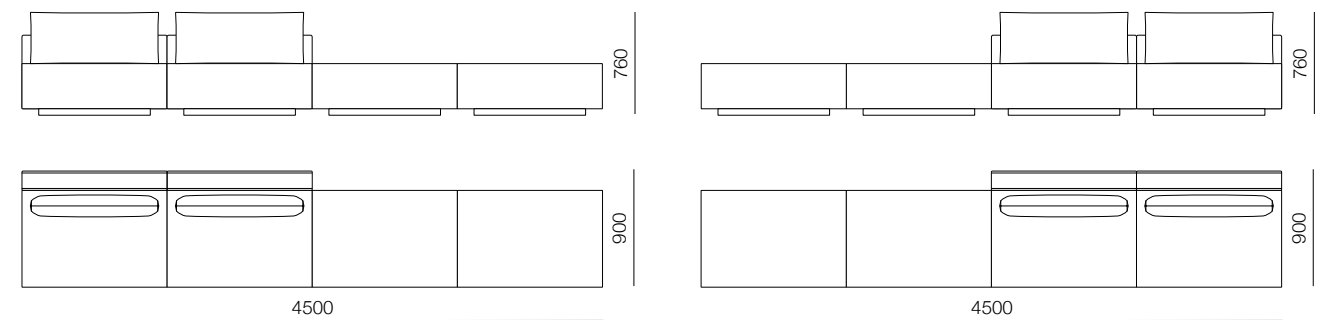

3.64
S_1125
B_1125
C_1000

3.65
S_1125
B_1125
C_1000

_ COMPOSITIONS_4 SEAT

_1125

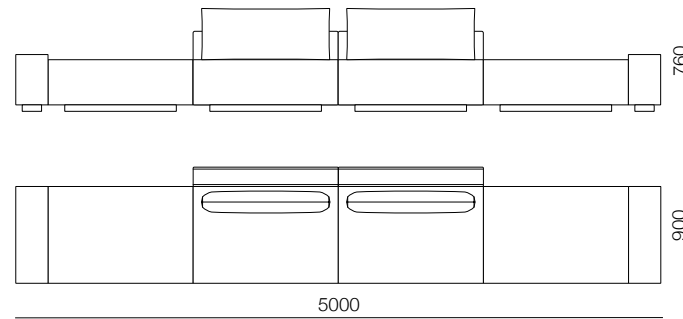

3.66

S_1125 A_S750
B_1125
C_1000

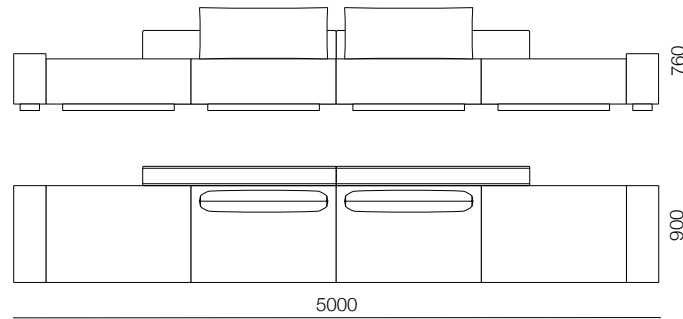

3.67

S_1125 A_S750
B_1500
C_1000

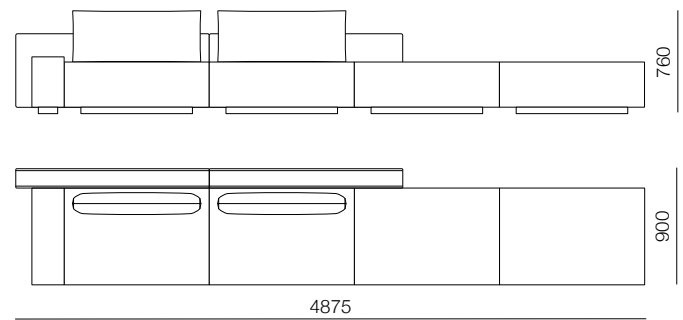

3.68

S_1125 A_S750
B_1500
C_1000

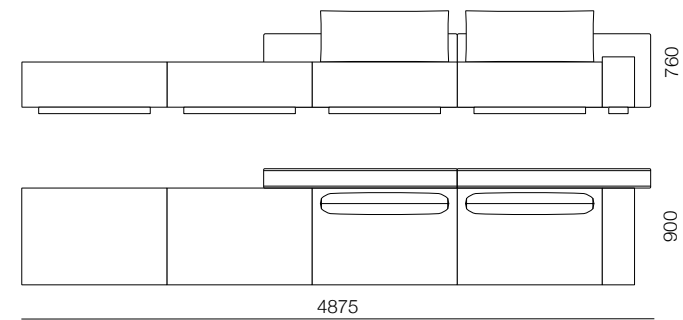

3.69

S_1125 A_S750
B_1500
C_1000

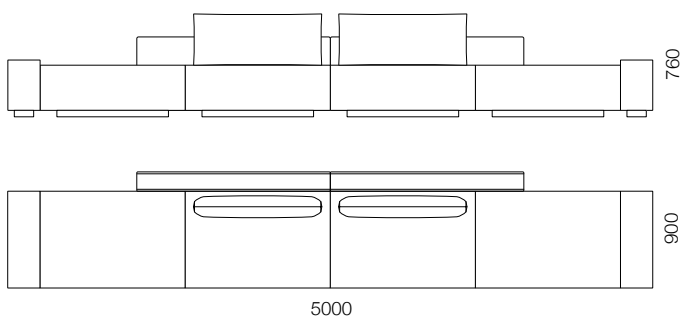

3.70

S_1125 A_S750
B_1500
C_1000

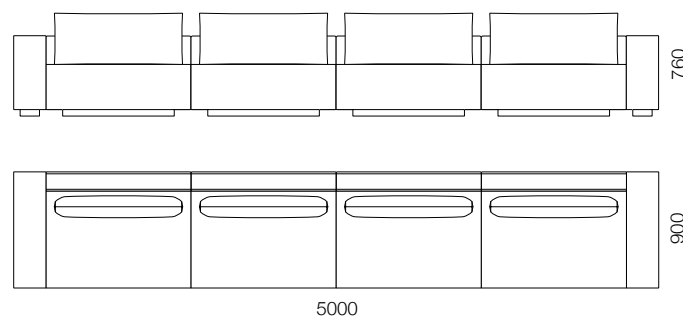

3.71

S_1125 A_H900
B_1125
C_1000

_ COMPOSITIONS_4 SEAT

_1125

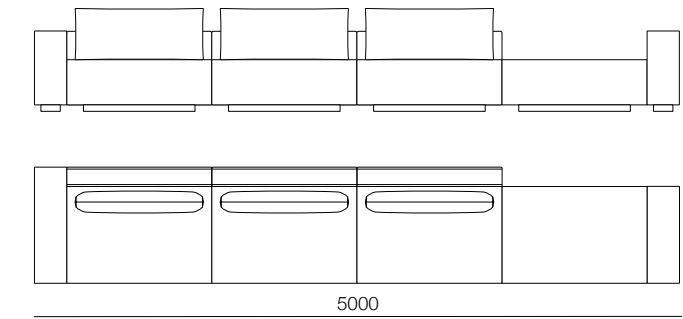

3.72

S_1125 A_H750
B_1125 A_H900
C_1000

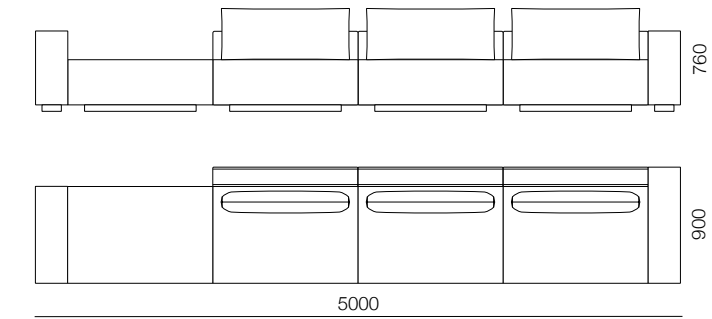

3.73

S_1125 A_H750
B_1125 A_H900
C_1000

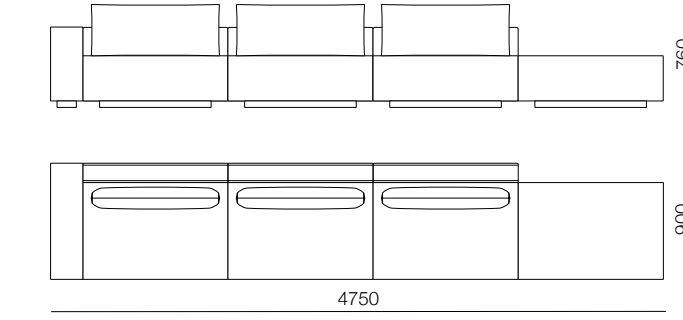

3.74

S_1125 A_H900
B_1125
C_1000

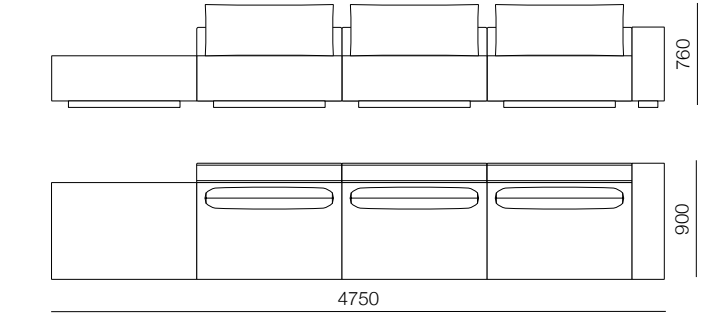

3.75

S_1125 A_H900
B_1125
C_1000

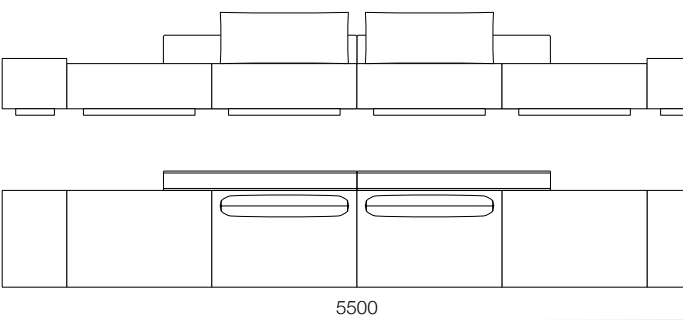

3.76

S_1125 A_W750
B_1500
C_1000

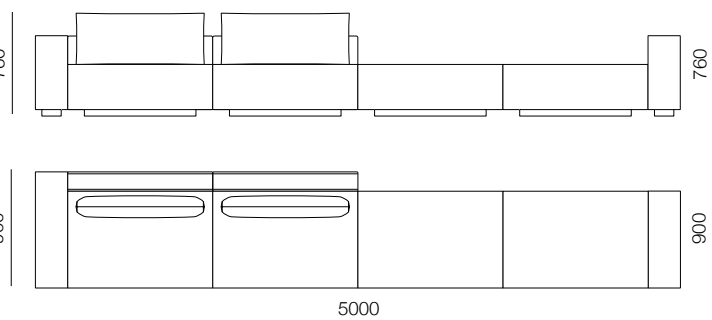

3.77

S_1125 A_H750
B_1125 A_H900
C_1000

_ COMPOSITIONS_4 SEAT

_1125

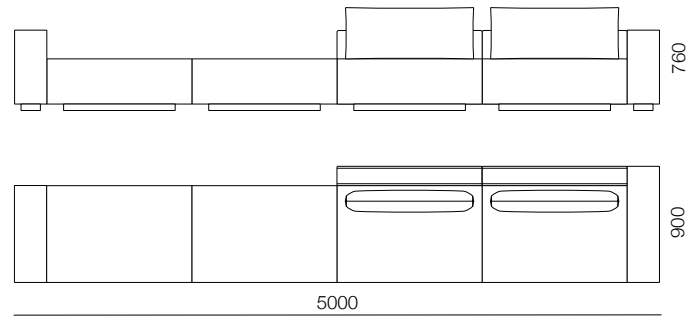

3.78

S_1125 A_H750
B_1125 A_H900
C_1000

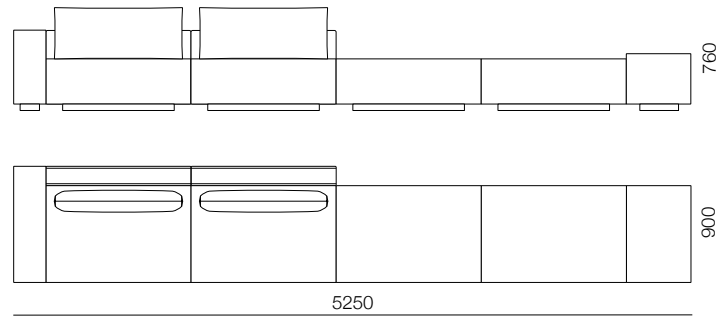

3.79

S_1125 A_W750
B_1125 A_H900
C_1000

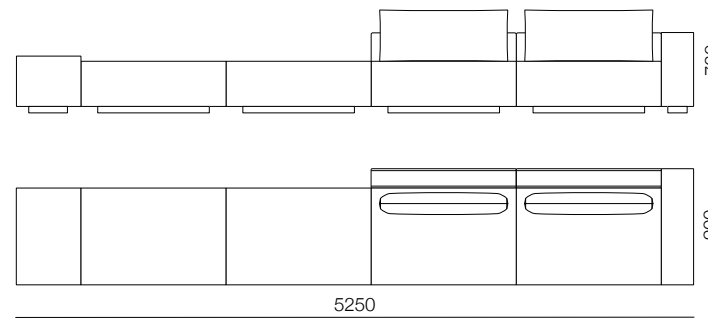

3.80

S_1125 A_W750
B_1125 A_H900
C_1000

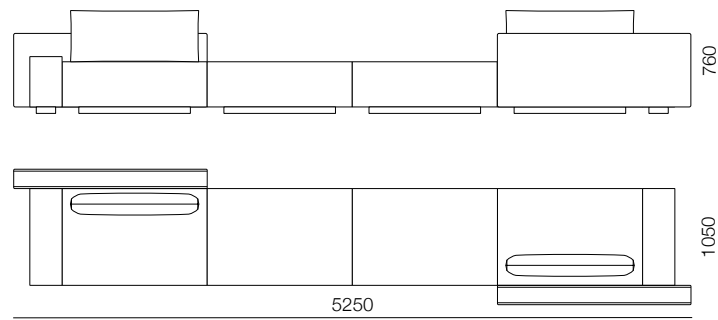

3.81

S_1125 A_S750
B_1500
C_1000

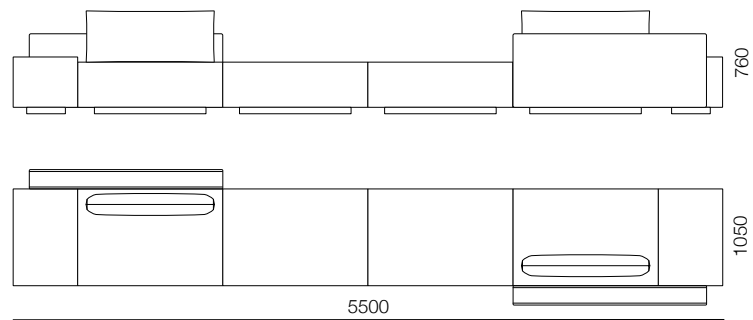

3.82

S_1125 A_W750
B_1500
C_1000

_ COMPOSITIONS_4 SEAT

_1500

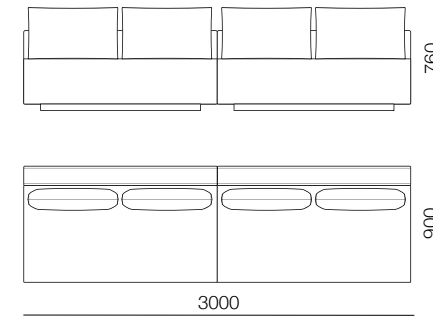

4.27

S_1500
B_1500
C_700

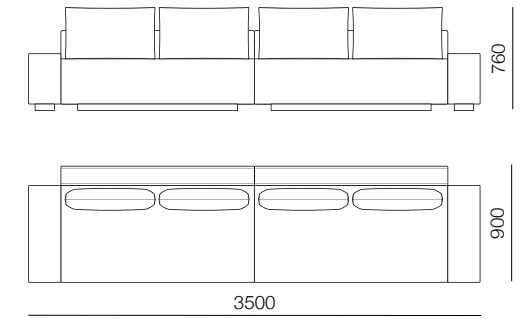

4.28

S_1500 A_S750
B_1500
C_700

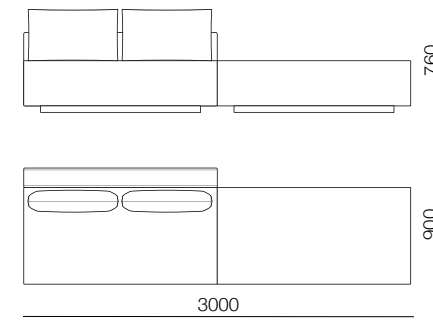

4.29

S_1500
B_1500
C_700

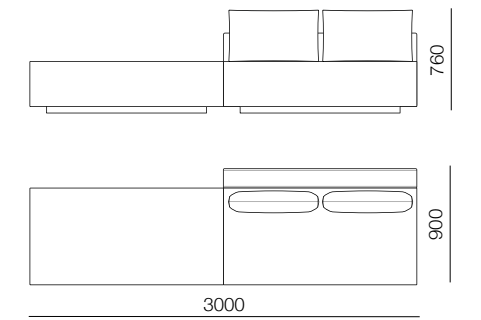

4.30

S_1500
B_1500
C_700

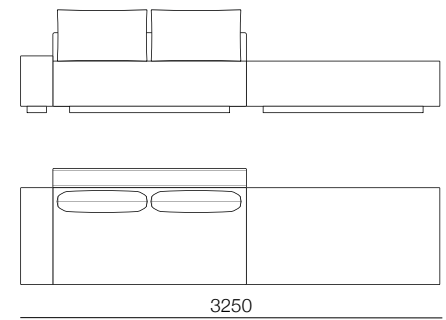

4.31

S_1500 A_S750
B_1500
C_700

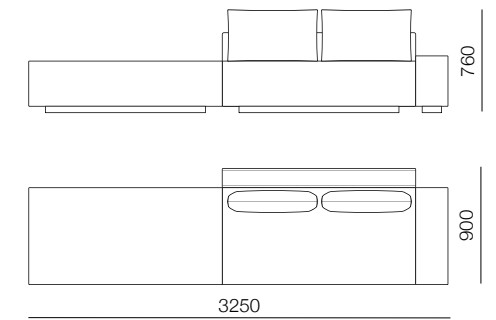

4.32

S_1500 A_S750
B_1500
C_700

_ COMPOSITIONS_4 SEAT

_1500

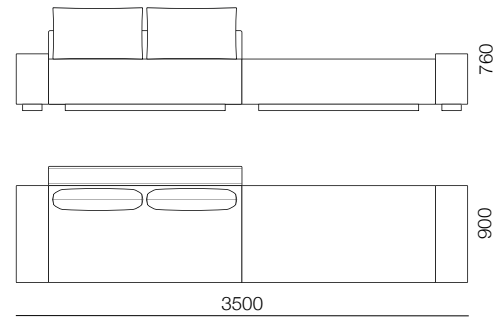

4.33
S_1500 A_S750
B_1500
C_700

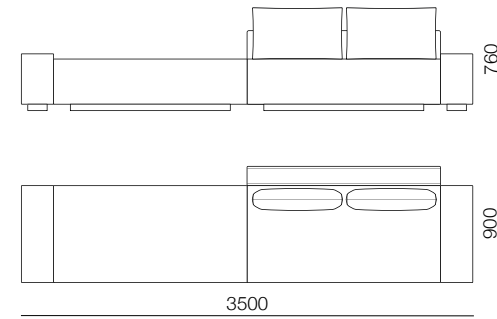

4.34
S_1500 A_S750
B_1500
C_700

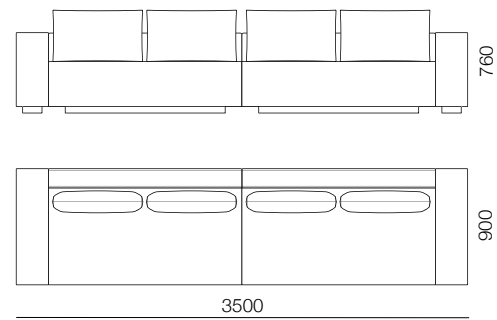

4.35
S_1500 A_H900
B_1500
C_700

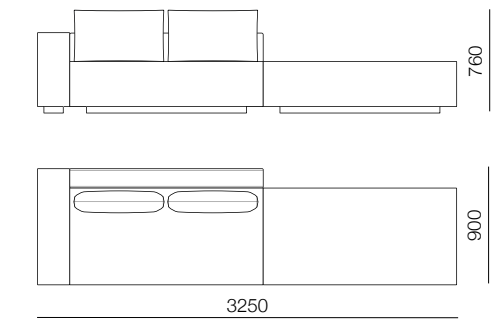

4.36
S_1500 A_H900
B_1500
C_700

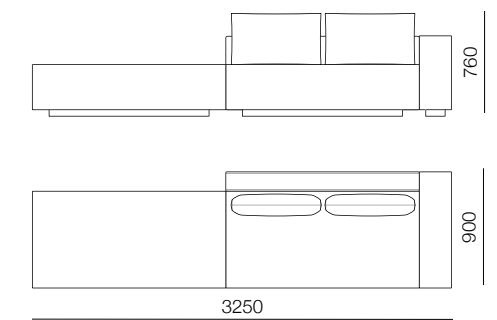

4.37
S_1500 A_H900
B_1500
C_700

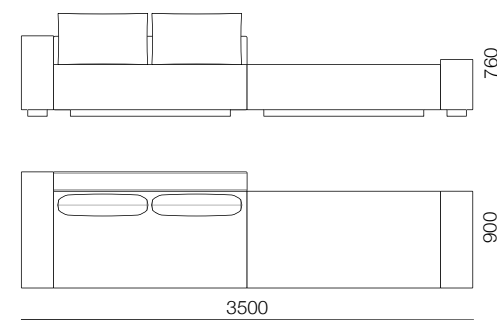

4.38
S_1500 A_S750
B_1500 A_H900
C_700

_ COMPOSITIONS_4 SEAT

_1500

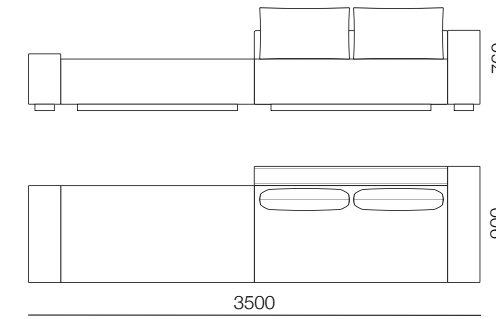

4.39
S_1500 A_S750
B_1500 A_H900
C_700

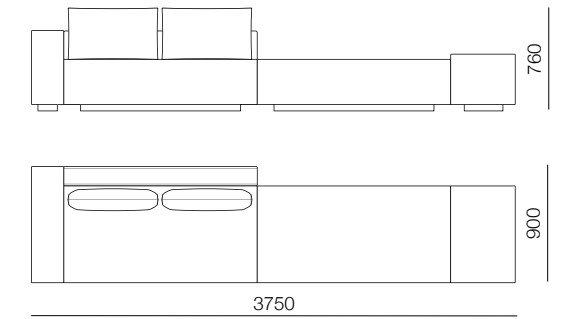

4.40
S_1500 A_W750
B_1500 A_H900
C_700

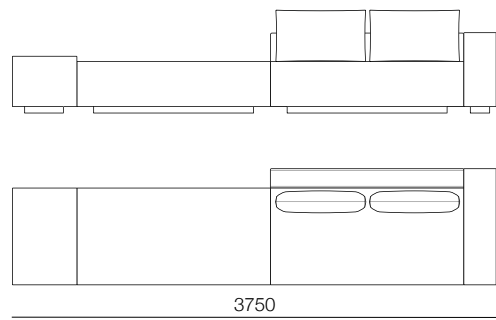

4.41
S_1500 A_W750
B_1500 A_H900
C_700

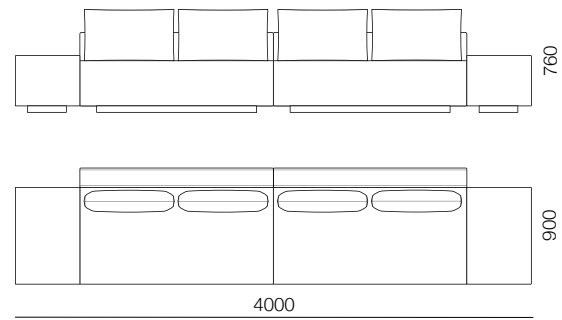

4.42
S_1500 A_W750
B_1500
C_700

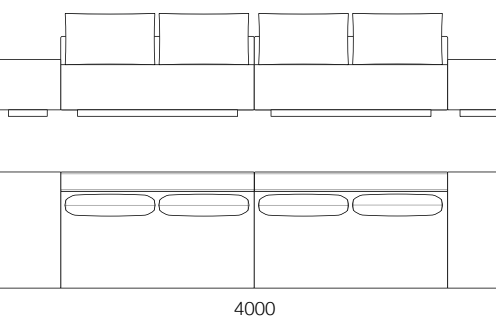

4.43
S_1500 A_W900
B_1500
C_700

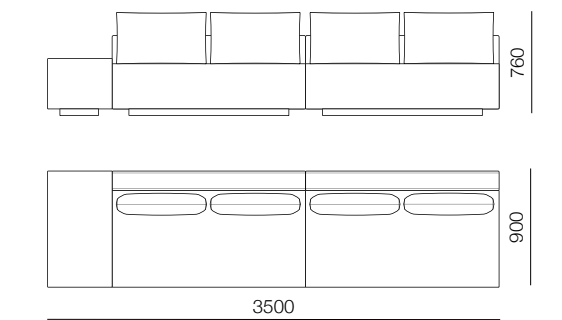

4.44
S_1500 A_W900
B_1500
C_700

_ COMPOSITIONS_4 SEAT

_1500

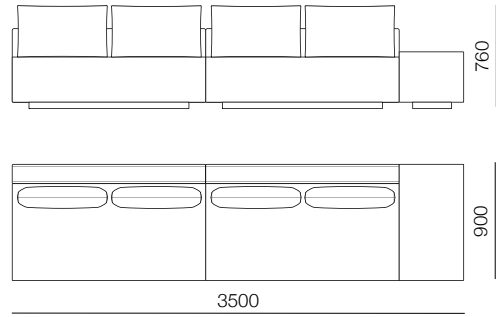

4.45
S_1500 A_W900
B_1500
C_700

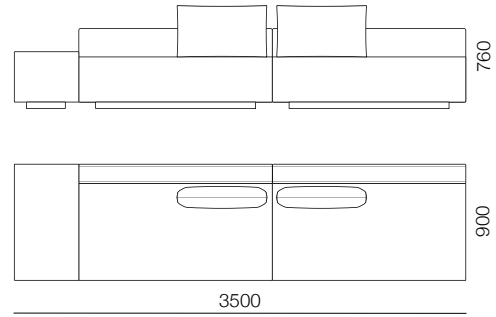

4.46
S_1500 A_W900
B_1500
C_700

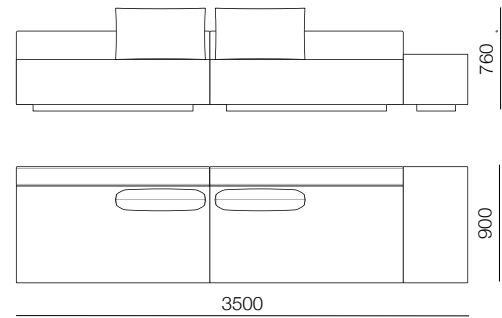

4.47
S_1500 A_W900
B_1500
C_700

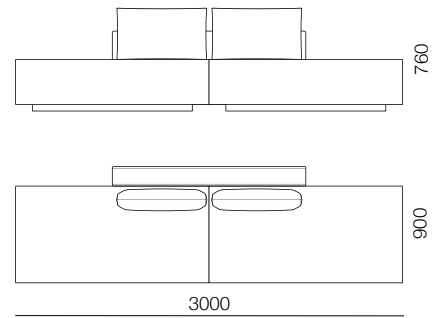

4.48
S_1500
B_1500
C_700

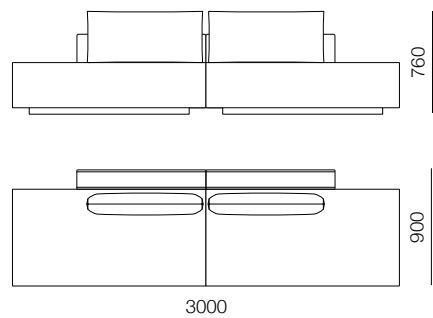

4.49
S_1500
B_1000
C_900

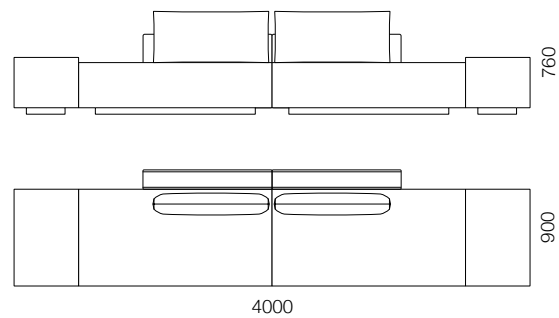

4.50
S_1500 A_W750
B_1000
C_900

_ COMPOSITIONS_4 SEAT

_1500

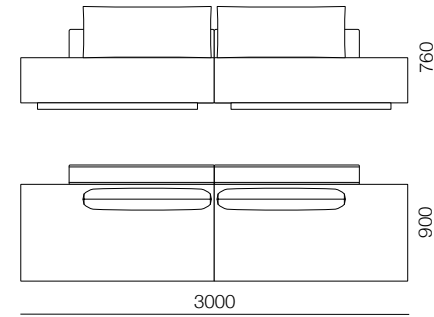

4.51
S_1500
B_1125
C_1000

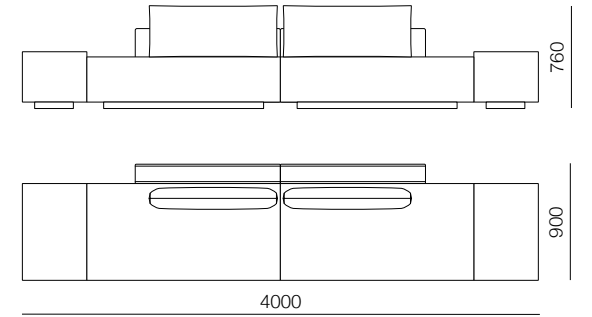

4.52
S_1500 A_W750
B_1125
C_1000

_ COMPOSITIONS_MODULAR

_750

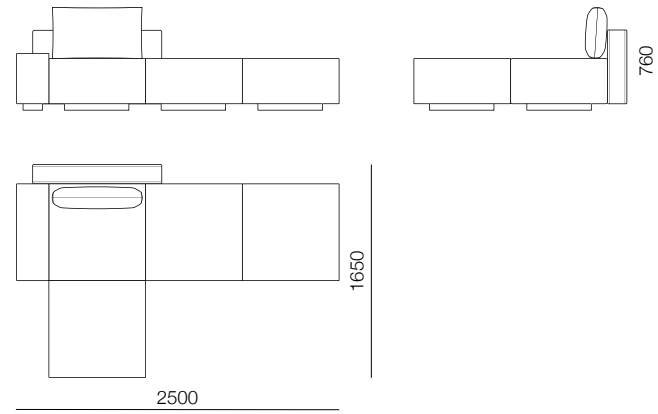

M.01
S_750 A_S750
B_1000
C_700

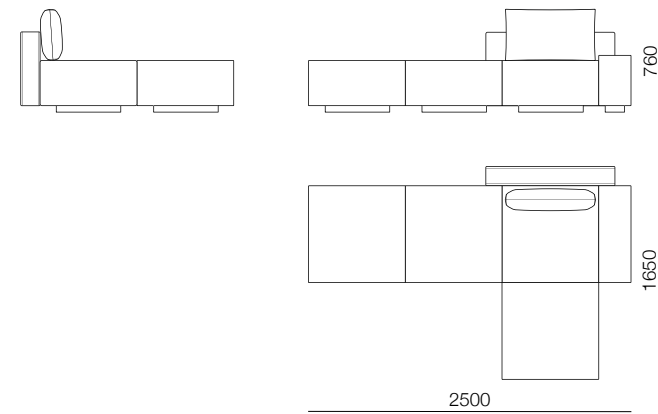

M.02
S_750 A_S750
B_1000
C_700

_ COMPOSITIONS_MODULAR

_750

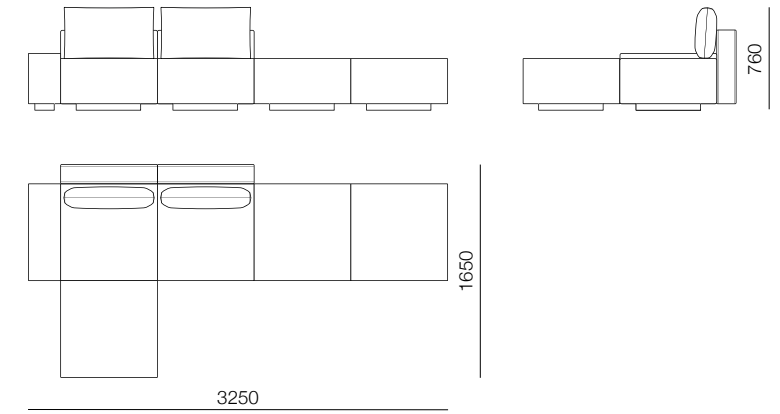

M.03
S_750 A_S750
B_750
C_700

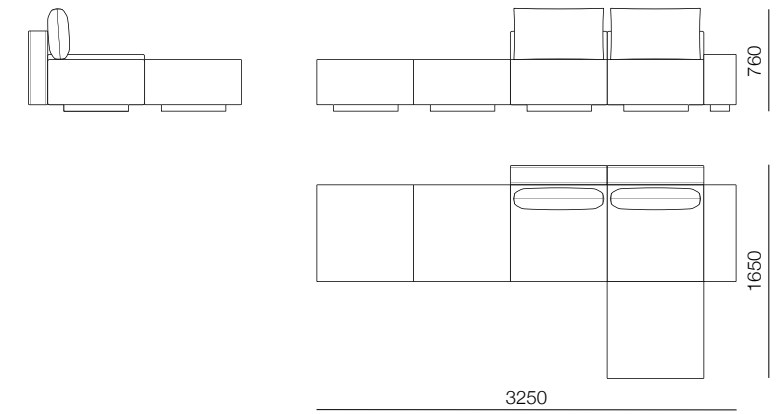

M.04
S_750 A_S750
B_750
C_700

_ COMPOSITIONS_MODULAR

_750

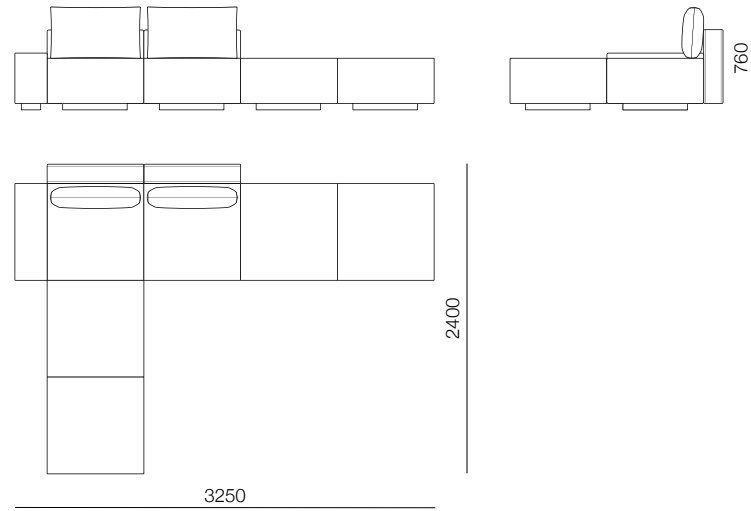

M.05
S_750 A_S750
B_750
C_700

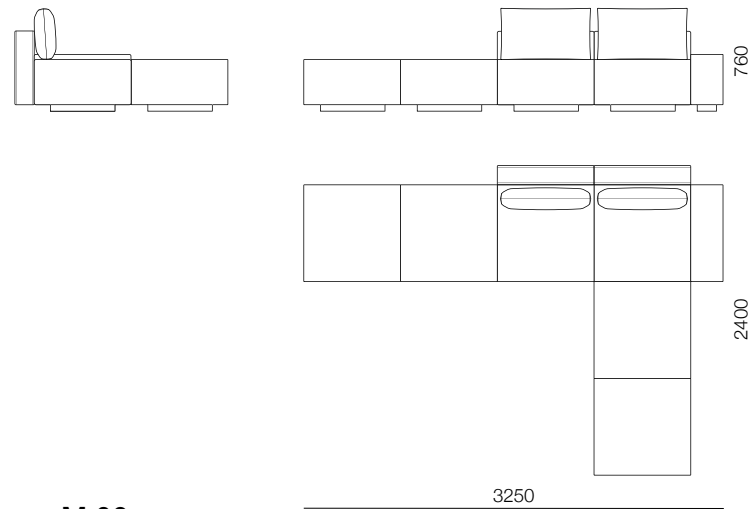

M.06
S_750 A_S750
B_750
C_700

_ COMPOSITIONS_MODULAR

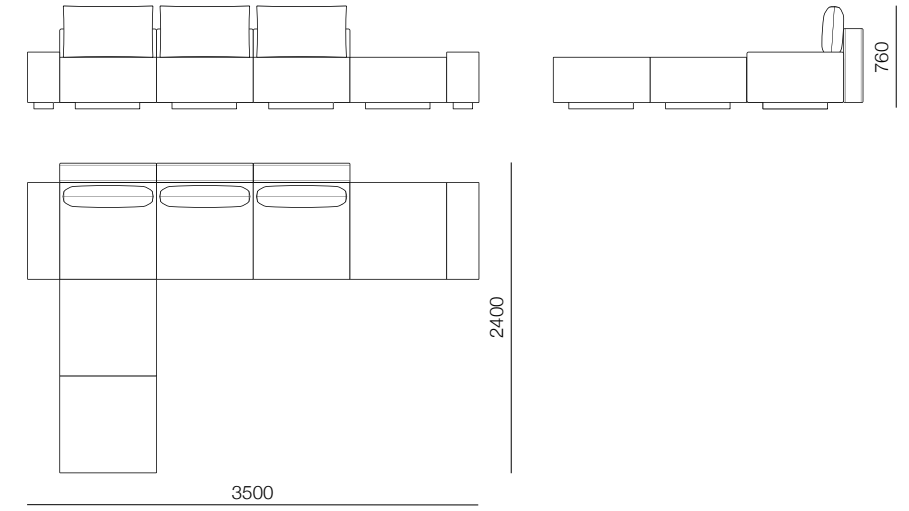

M.07
S_750 A_S750
B_750
C_700

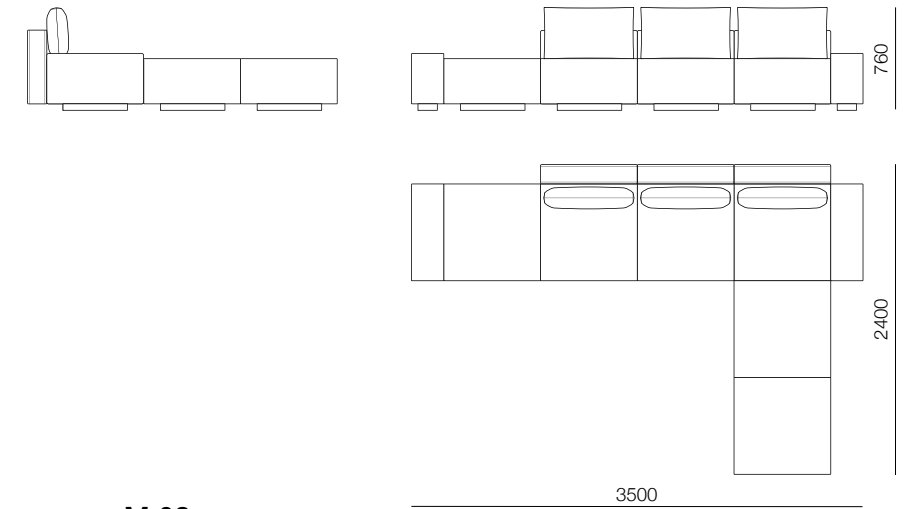

M.08
S_750 A_S750
B_750
C_700

_ COMPOSITIONS_MODULAR

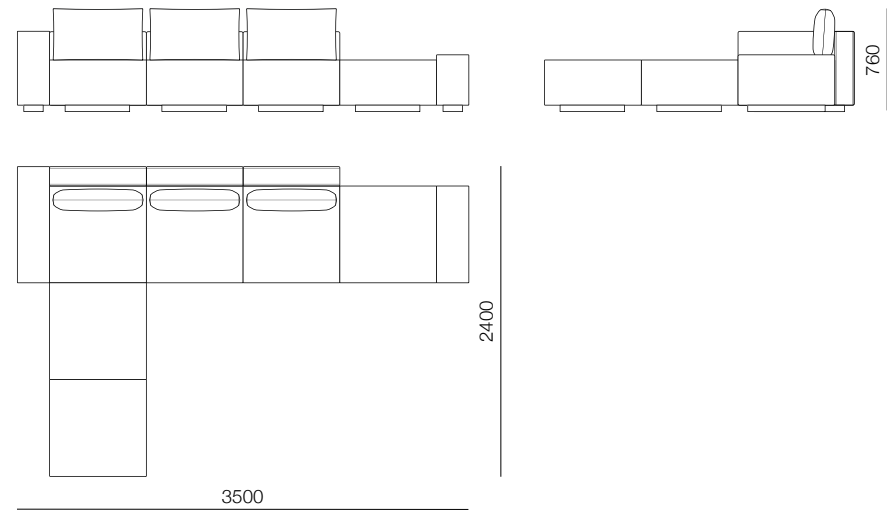

M.09
 S_750 A_H900
 B_750 A_S750
 C_700

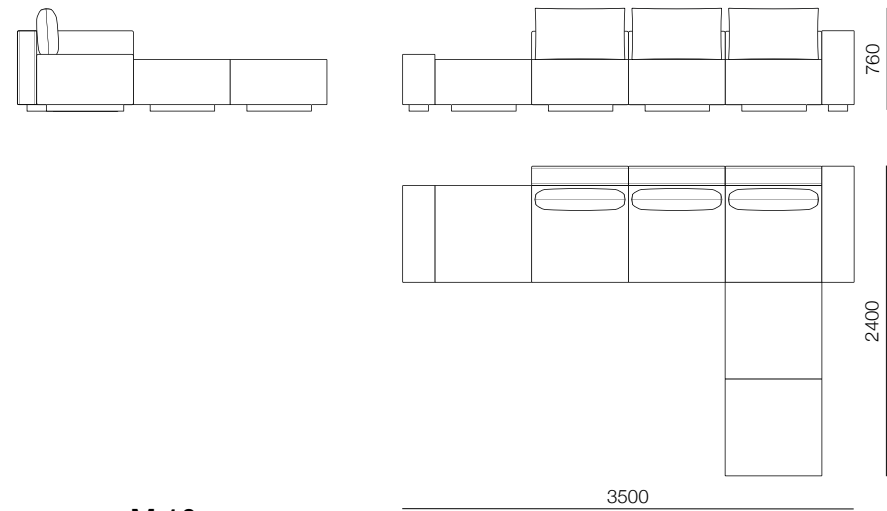

M.10
 S_750 A_H900
 B_750 A_S750
 C_700

_ COMPOSITIONS_MODULAR

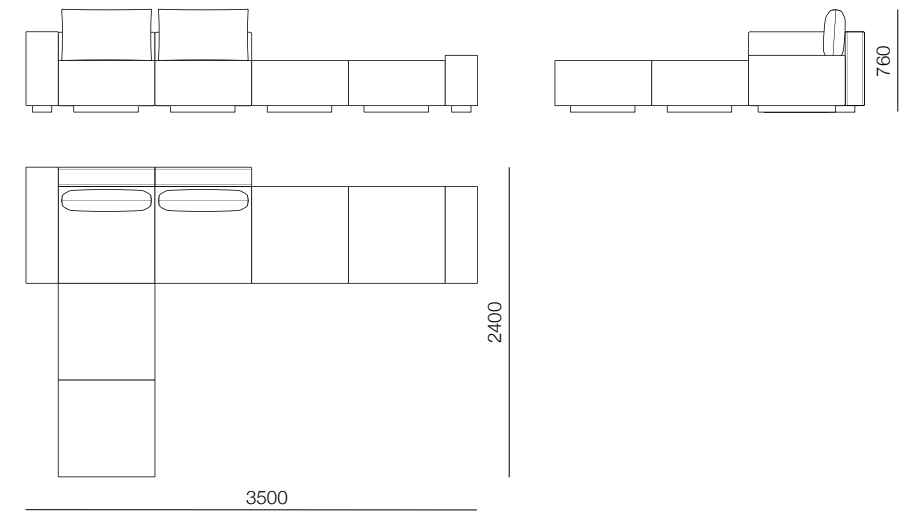

M.11
 S_750 A_H900
 B_750 A_S750
 C_700

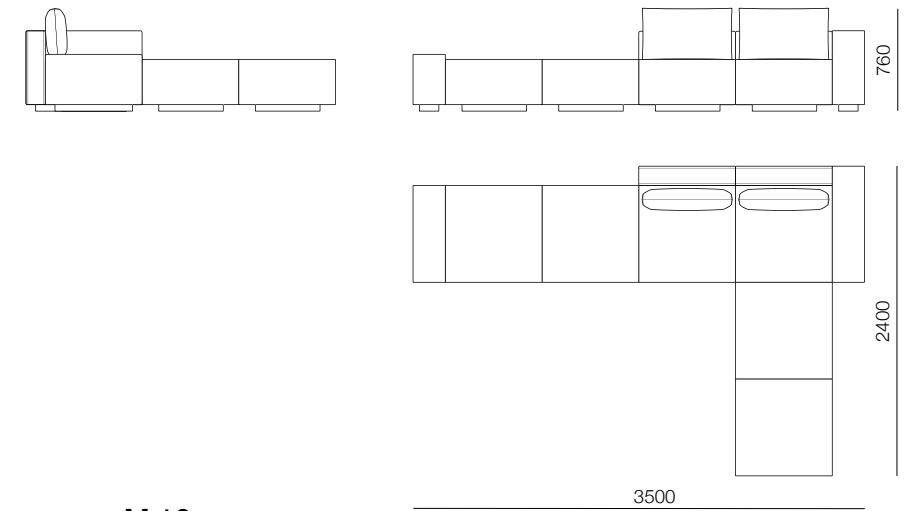

M.12
 S_750 A_H900
 B_750 A_S750
 C_700

_ COMPOSITIONS_MODULAR

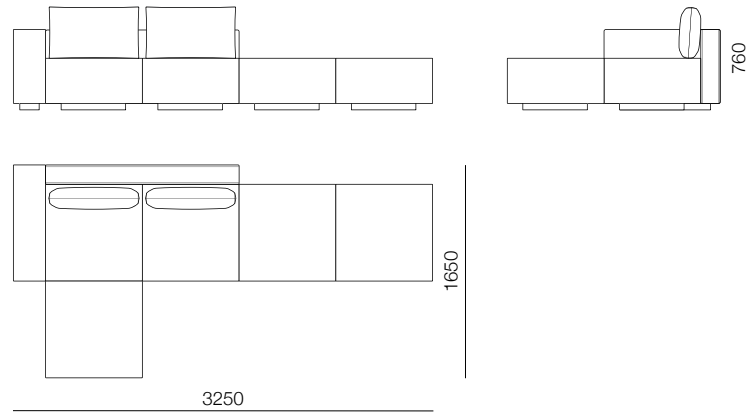

M.13
S_750 A_H900
B_1500
C_700

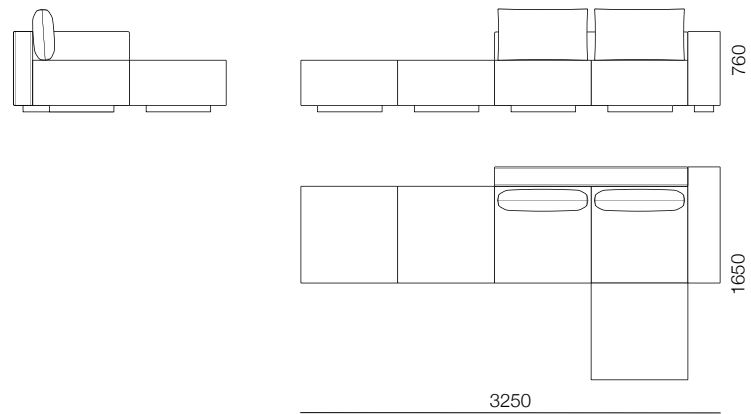

M.14
S_750 A_H900
B_1500
C_700

_ COMPOSITIONS_MODULAR

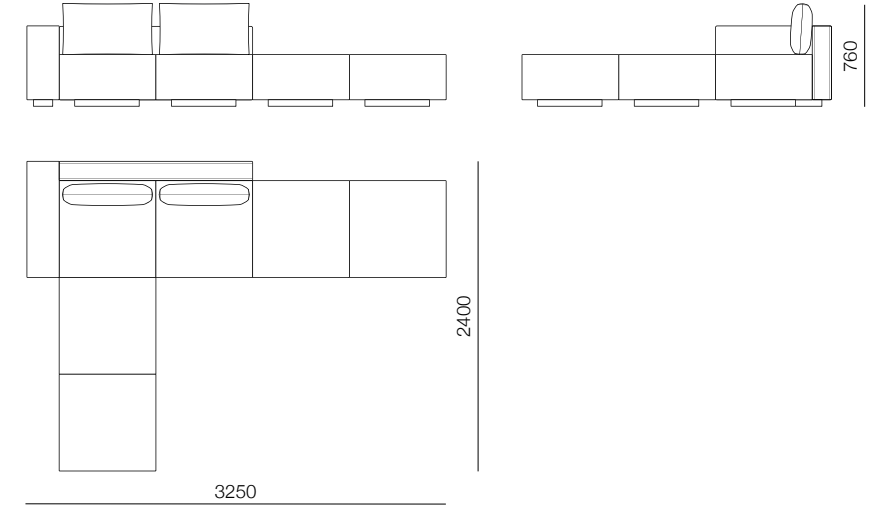

M.15
S_750 A_H900
B_1500
C_700

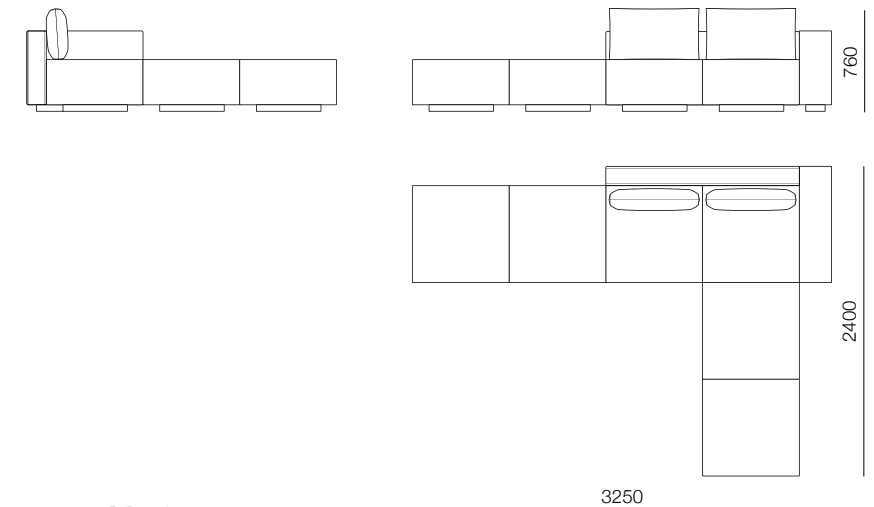

M.16
S_750 A_H900
B_1500
C_700

_ COMPOSITIONS_MODULAR

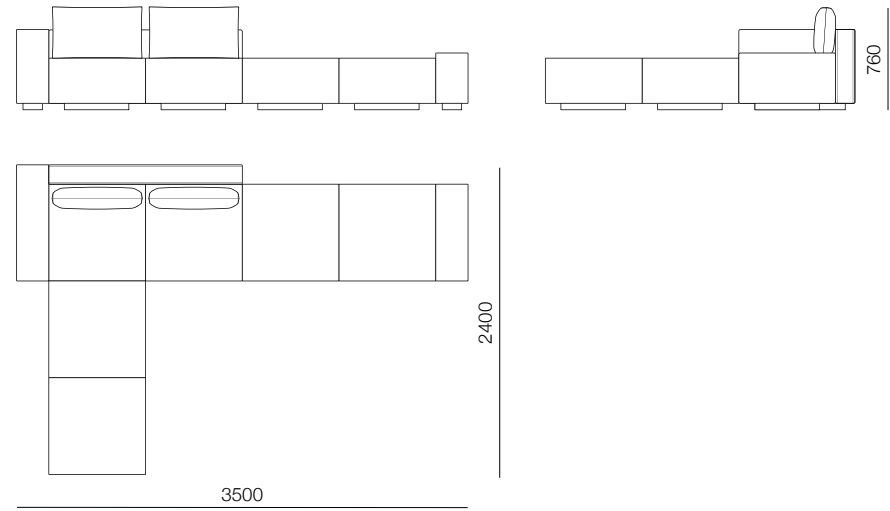

M.17
 S_750 A_H900
 B_1500 A_S750
 C_700

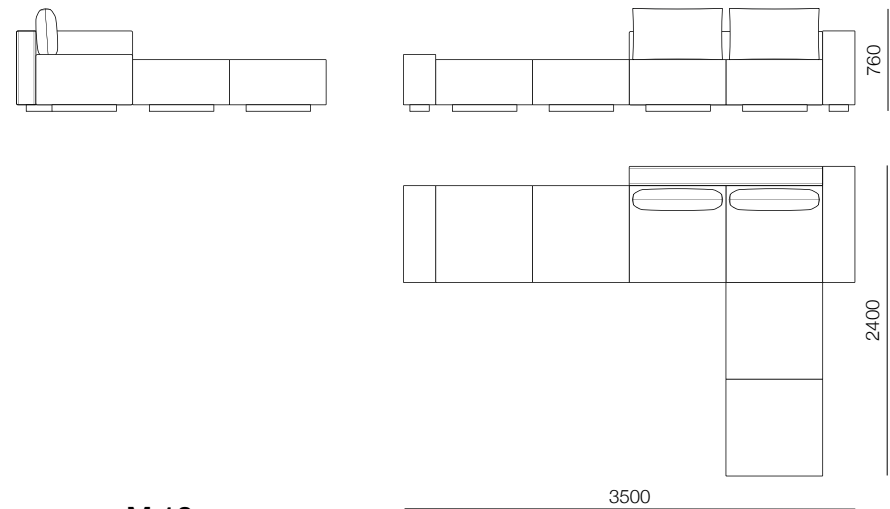

M.18
 S_750 A_H900
 B_1500 A_S750
 C_700

_ COMPOSITIONS_MODULAR

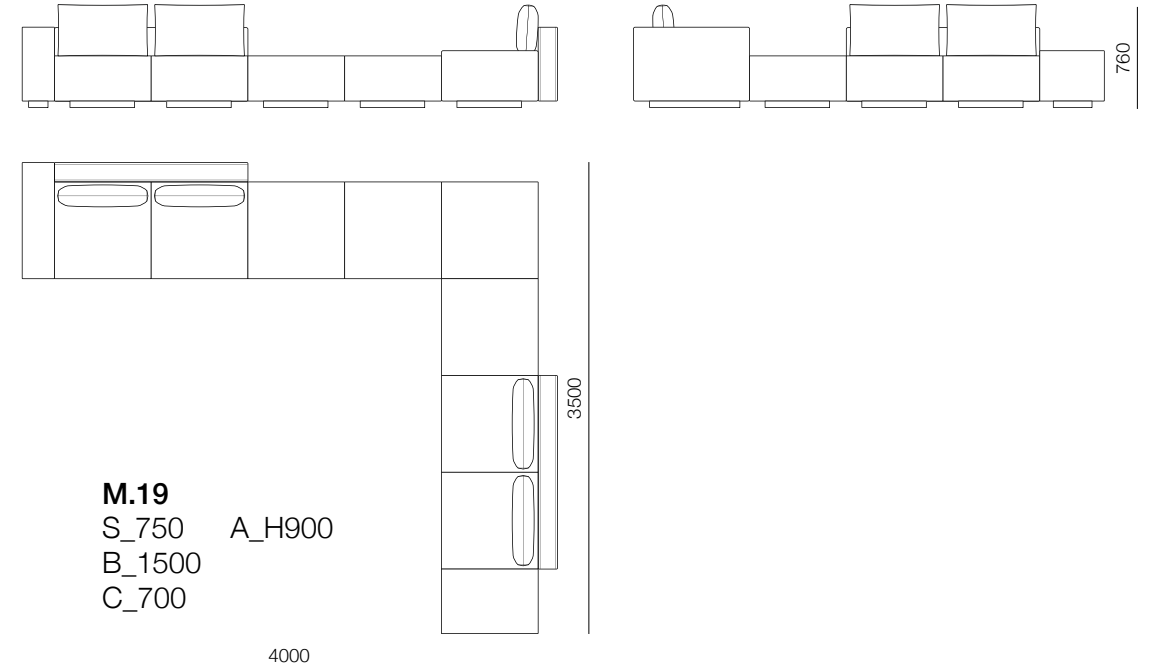

M.19
 S_750 A_H900
 B_1500
 C_700

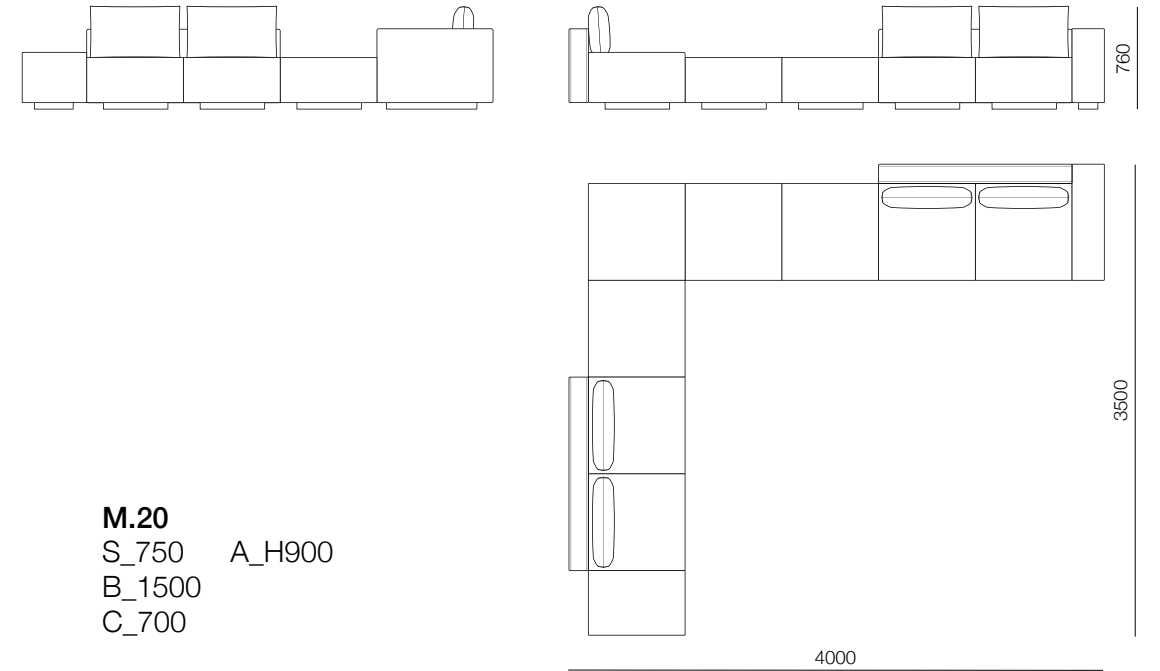

M.20
 S_750 A_H900
 B_1500
 C_700

_ COMPOSITIONS_MODULAR

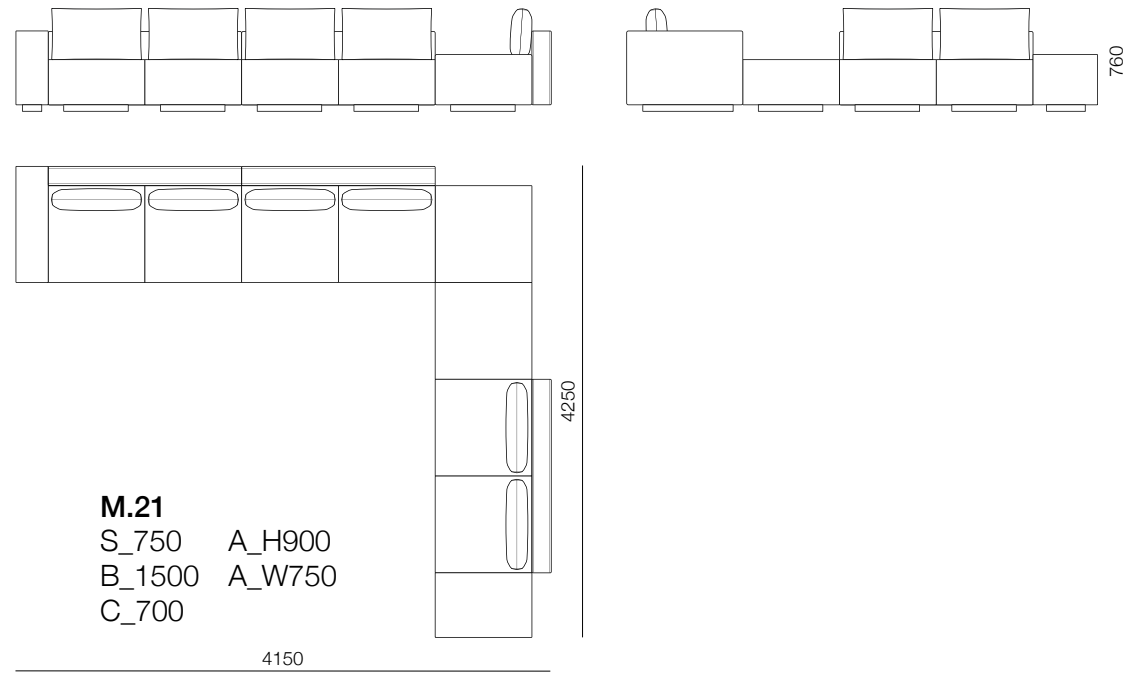

M.21
 S_750 A_H900
 B_1500 A_W750
 C_700

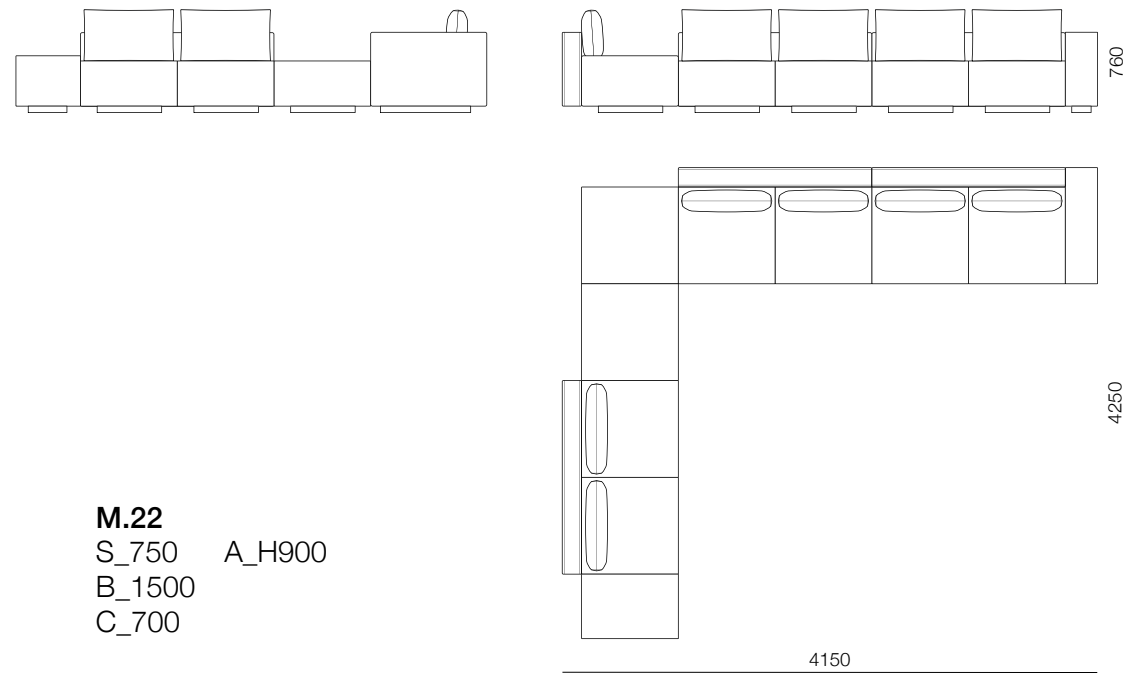

M.22
 S_750 A_H900
 B_1500
 C_700

_ COMPOSITIONS_MODULAR

_1000

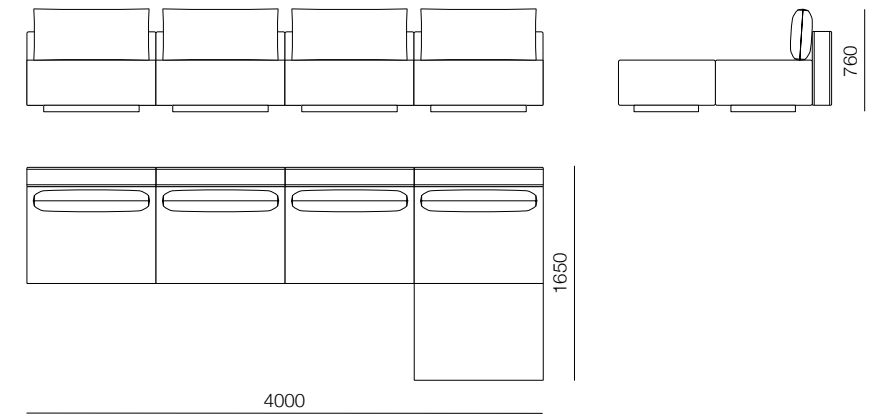

M.23
 S_1000
 B_1000
 C_900

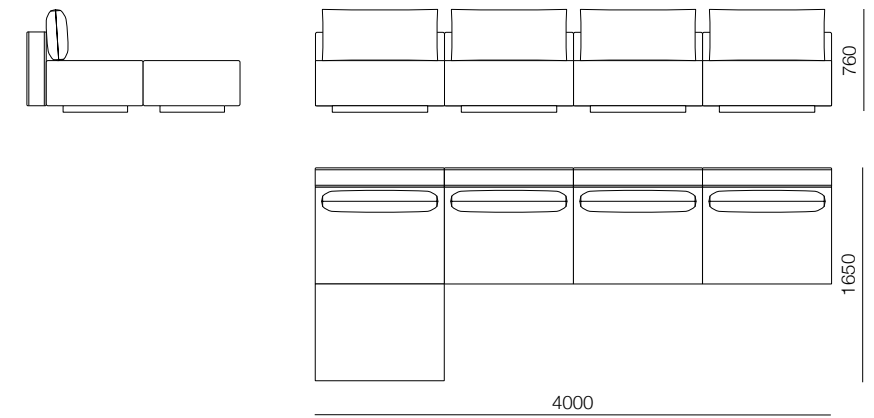

M.24
 S_1000
 B_1000
 C_900

_ COMPOSITIONS_MODULAR

_1000

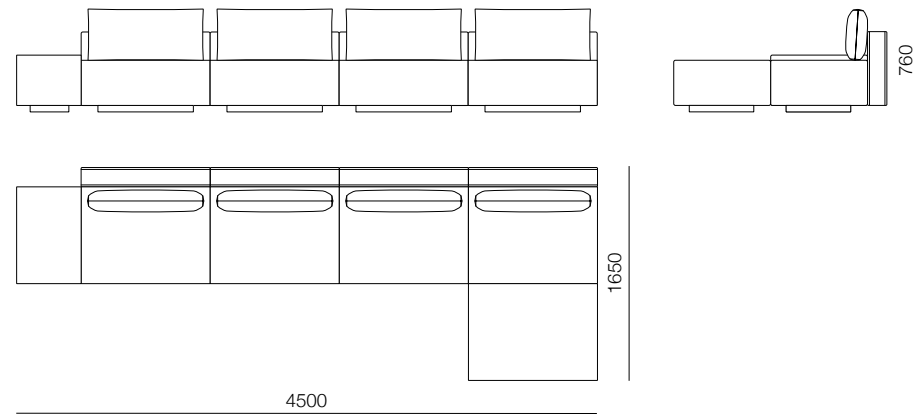

M.25
S_1000 A_W750
B_1000
C_700

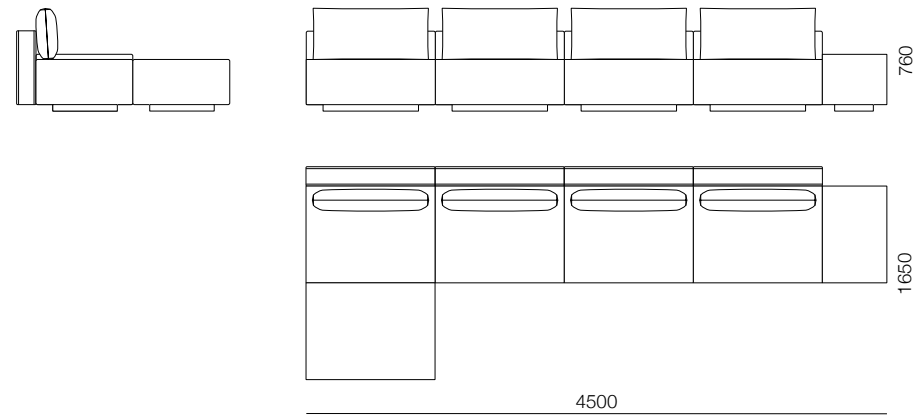

M.26
S_1000 A_W750
B_1000
C_700

_ COMPOSITIONS_MODULAR

_1000

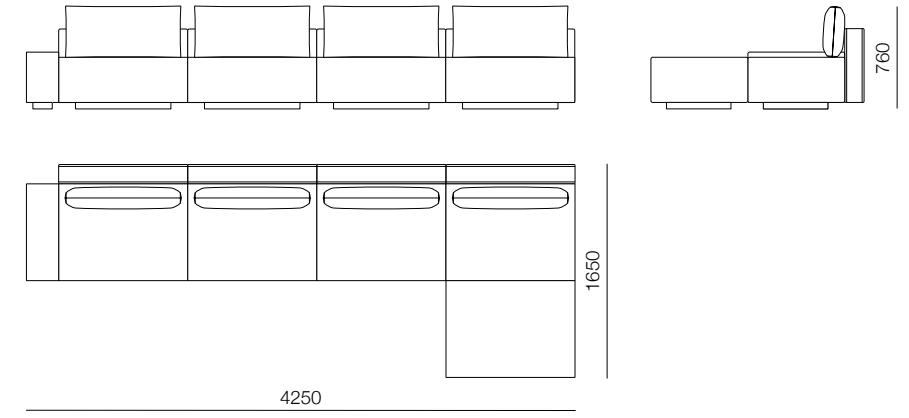

M.27
S_1000 A_S750
B_1000
C_900

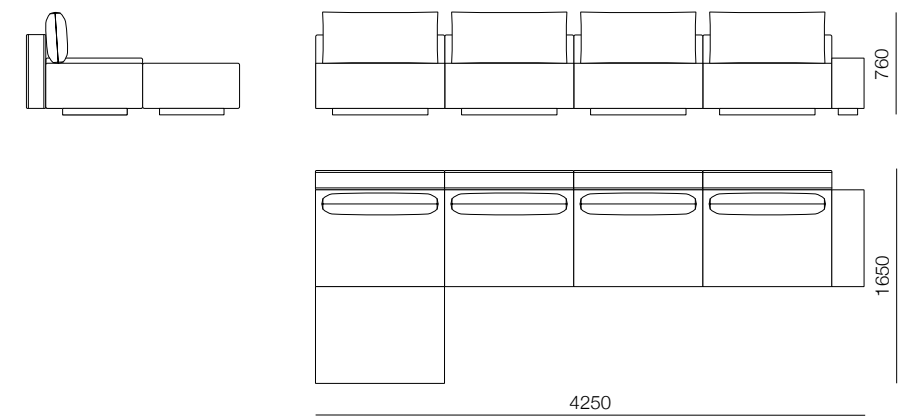

M.28
S_1000 A_S750
B_1000
C_900

_ COMPOSITIONS_MODULAR

_1000

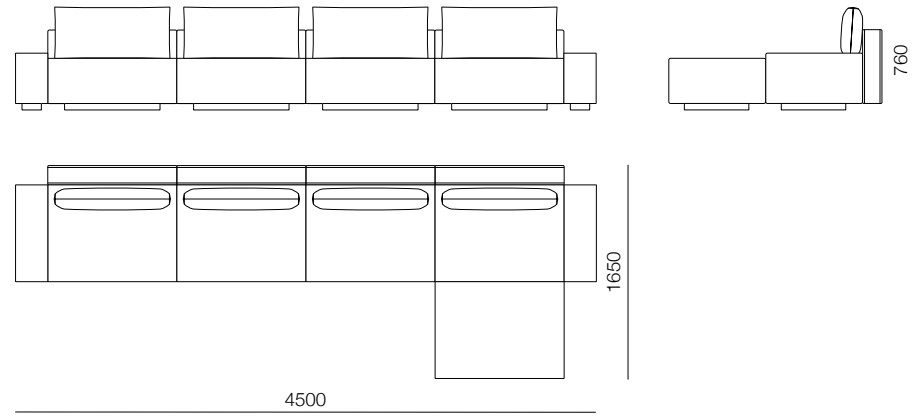

M.29
S_1000 A_S750
B_1000
C_900

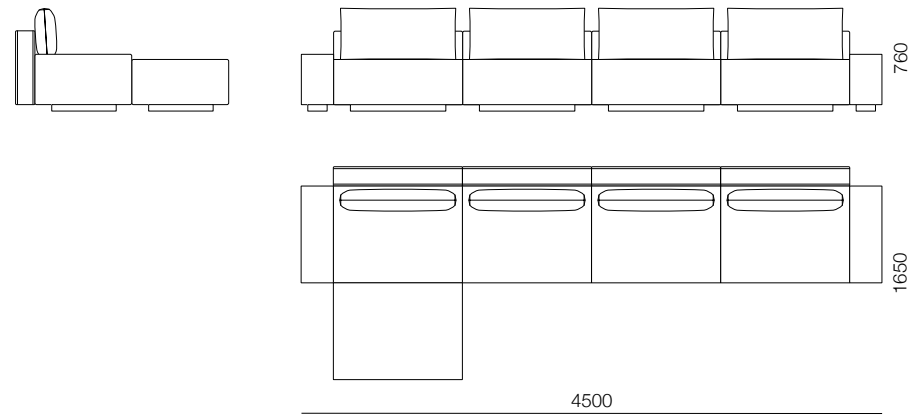

M.30
S_1000 A_S750
B_1000
C_900

_ COMPOSITIONS_MODULAR

_1000

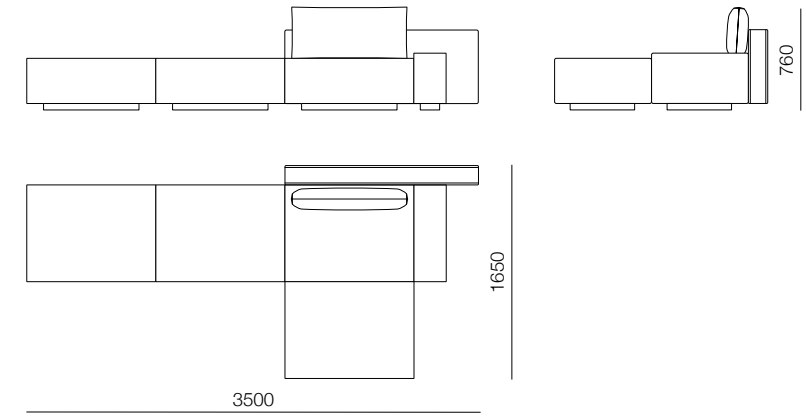

M.31
S_1000 A_S750
B_1500
C_900

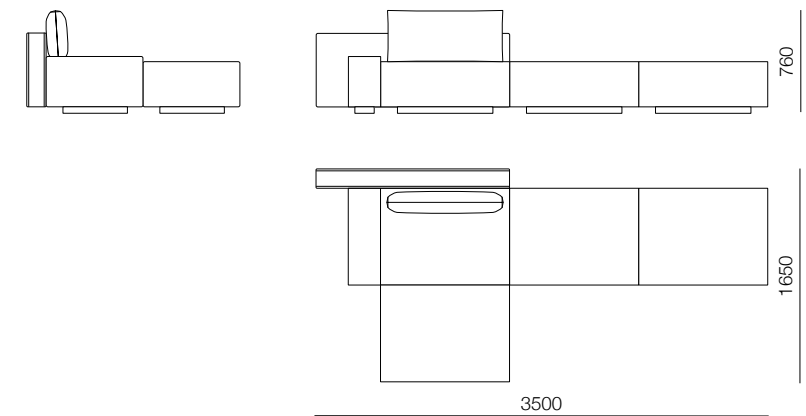

M.32
S_1000 A_S750
B_1500
C_900

_ COMPOSITIONS_MODULAR

_1000

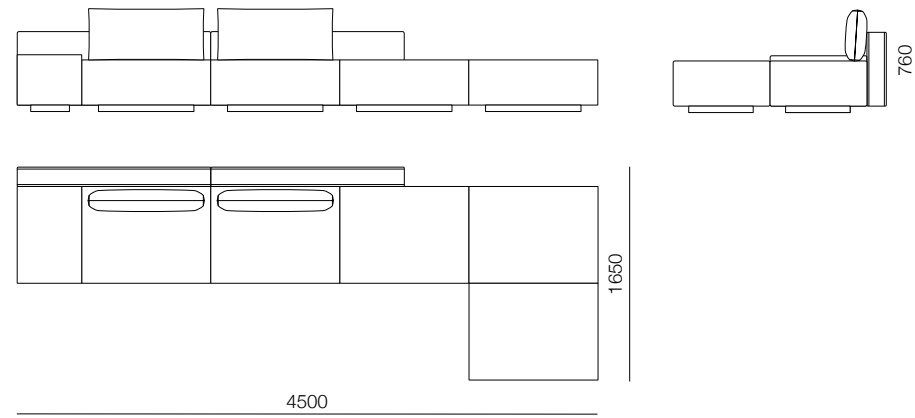

M.33
S_1000 A_W750
B_1500
C_900

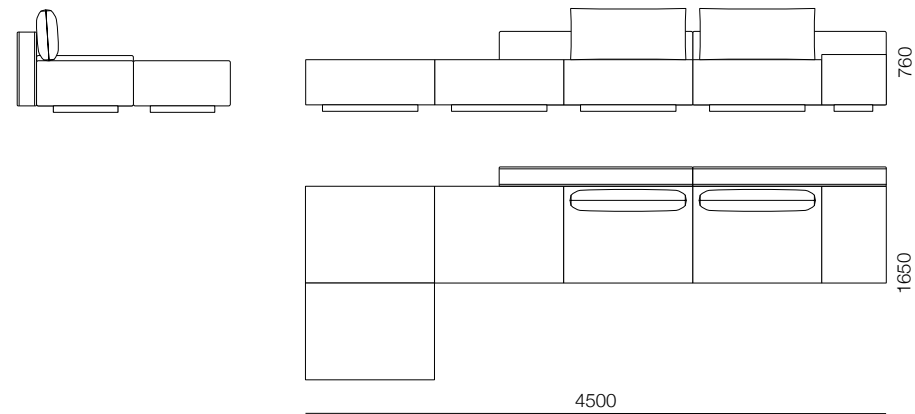

M.34
S_1000 A_W750
B_1500
C_900

_ COMPOSITIONS_MODULAR

_1000

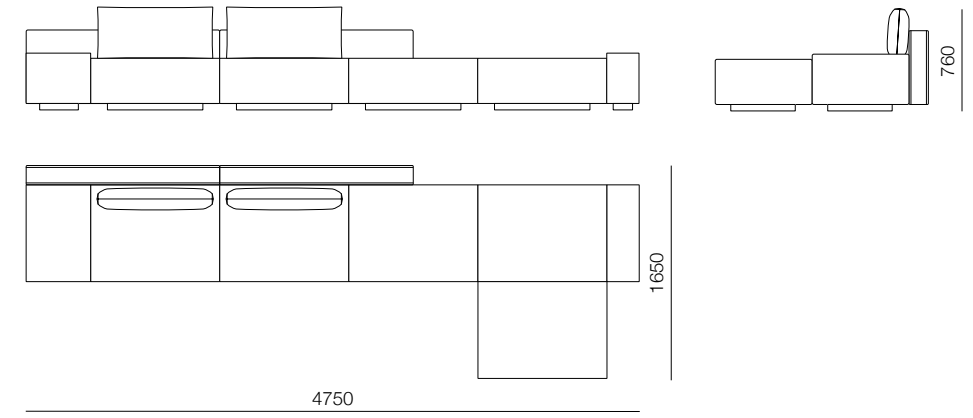

M.35
S_1000 A_W750
B_1500 A_S750
C_900

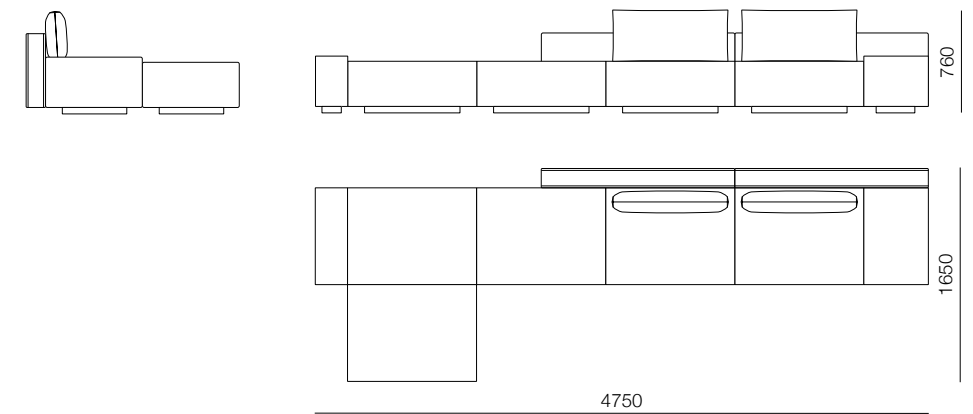

M.36
S_1000 A_W750
B_1500 A_S750
C_900

_ COMPOSITIONS_MODULAR

_1000

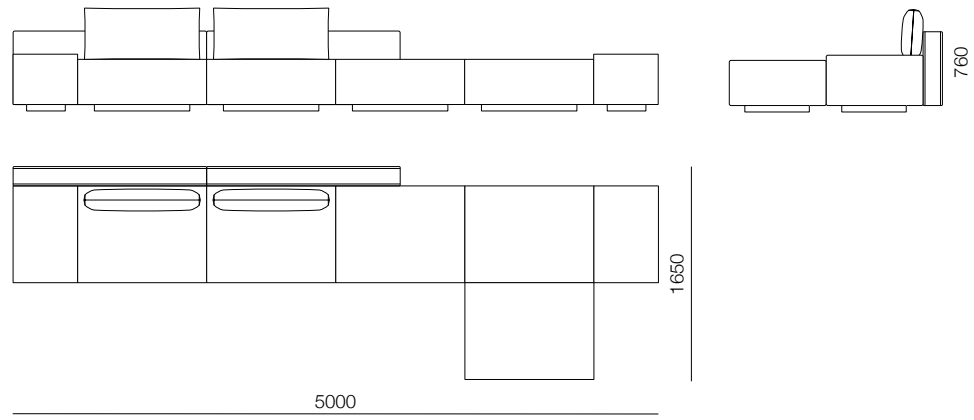

M.37
S_1000 A_W750
B_1500
C_900

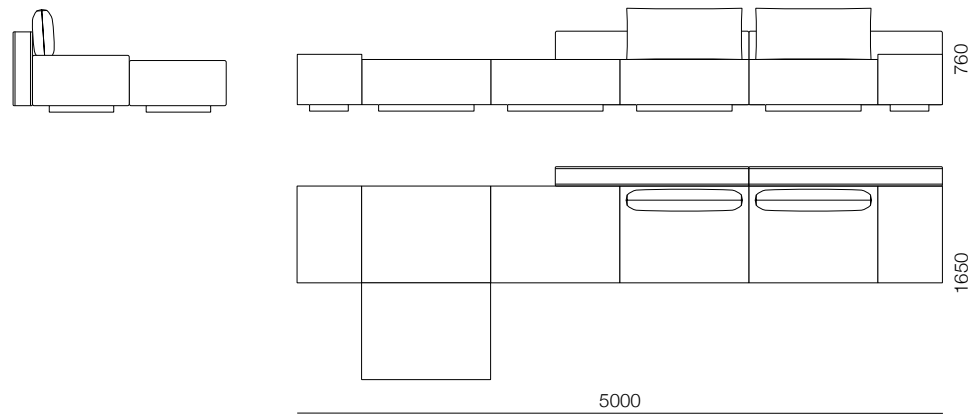

M.38
S_1000 A_W750
B_1500
C_900

_ COMPOSITIONS_MODULAR

_1125

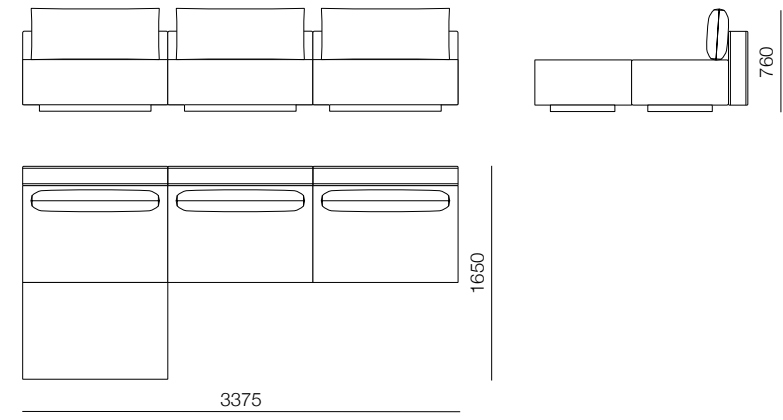

M.39
S_1000
B_1000
C_900

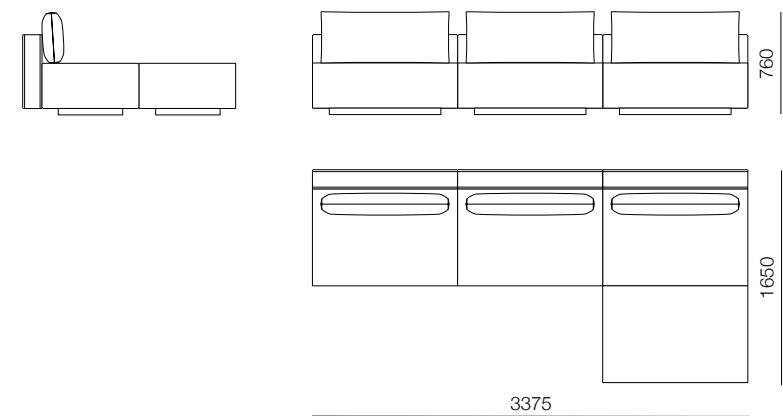

M.40
S_1000
B_1000
C_900

_ COMPOSITIONS_MODULAR

_1125

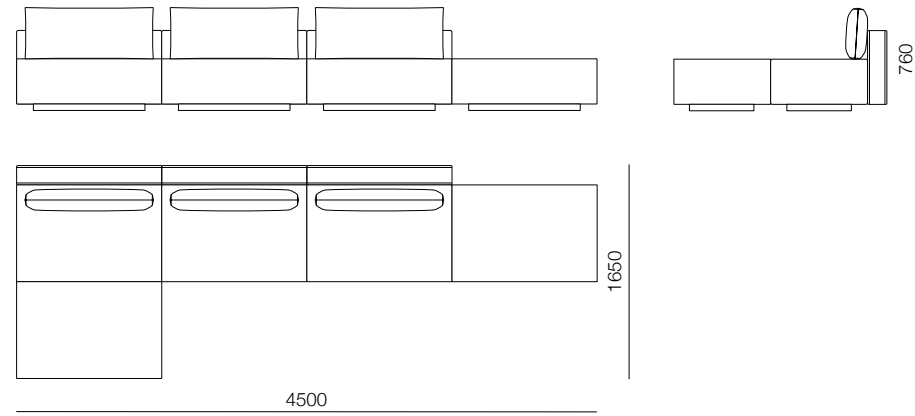

M.41
S_1125
B_1125
C_1000

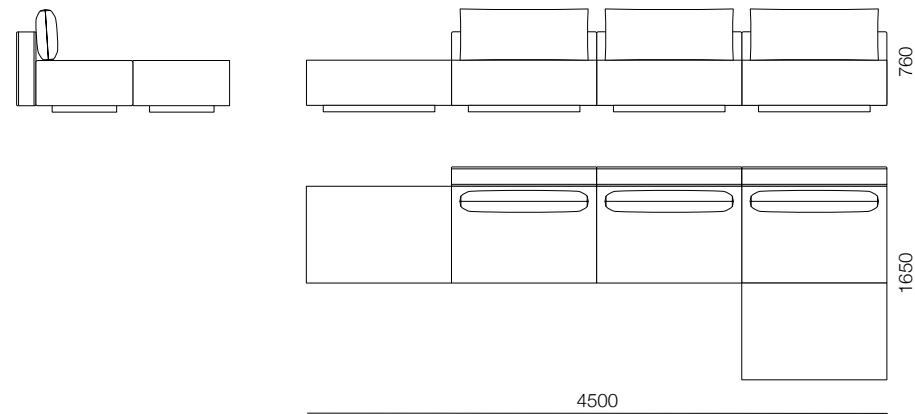

M.42
S_1125
B_1125
C_1000

_ COMPOSITIONS_MODULAR

_1125

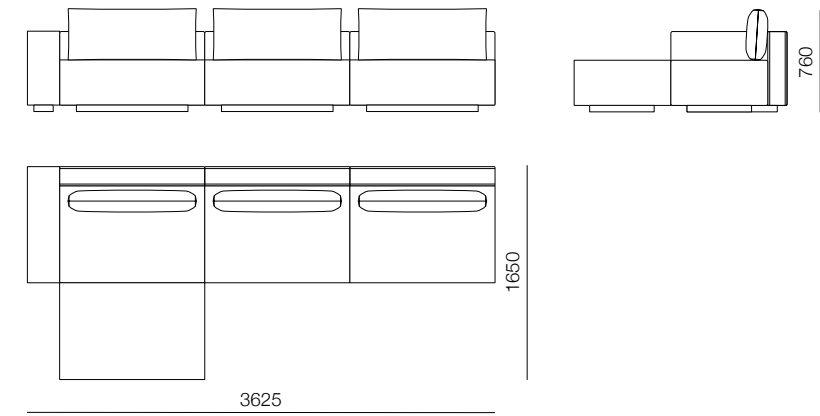

M.43
S_1125 A_H900
B_1125
C_1000

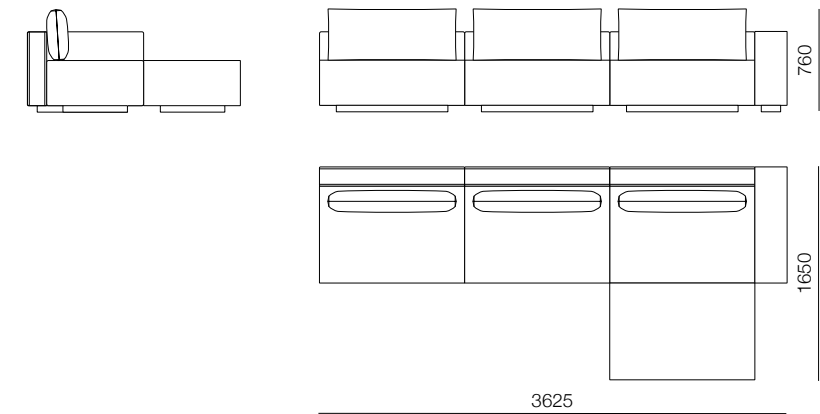

M.44
S_1125 A_H900
B_1125
C_1000

_ COMPOSITIONS_MODULAR

_1125

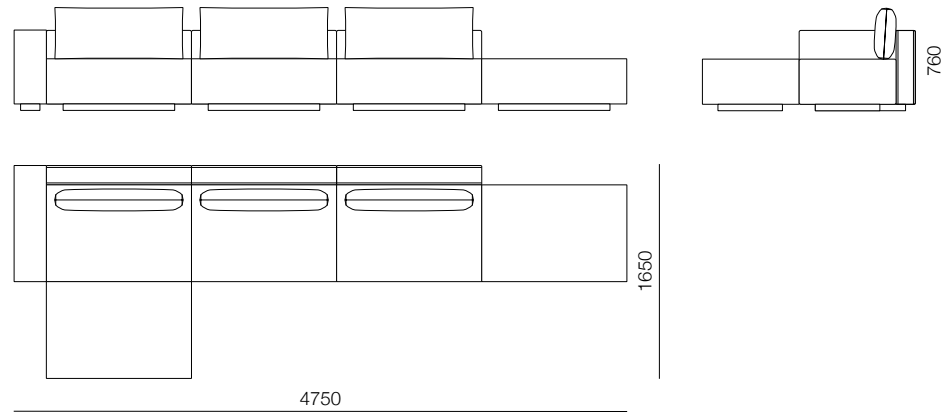

M.45
S_1125 A_H900
B_1125
C_1000

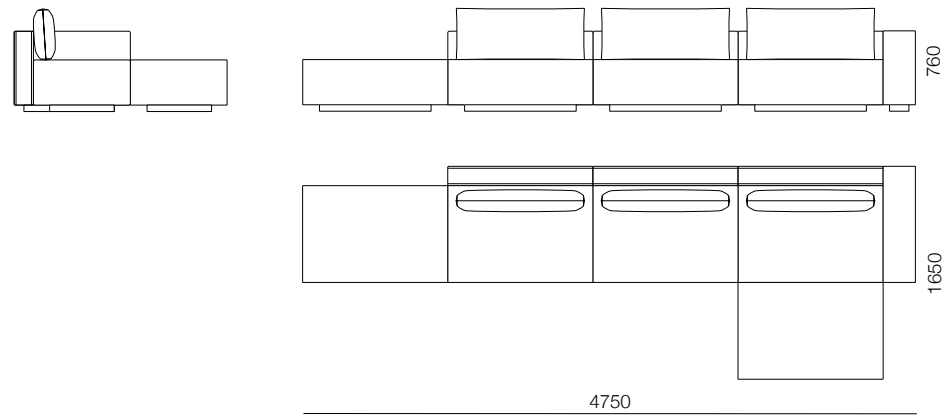

M.46
S_1125 A_H900
B_1125
C_1000

_ COMPOSITIONS_MODULAR

_1125

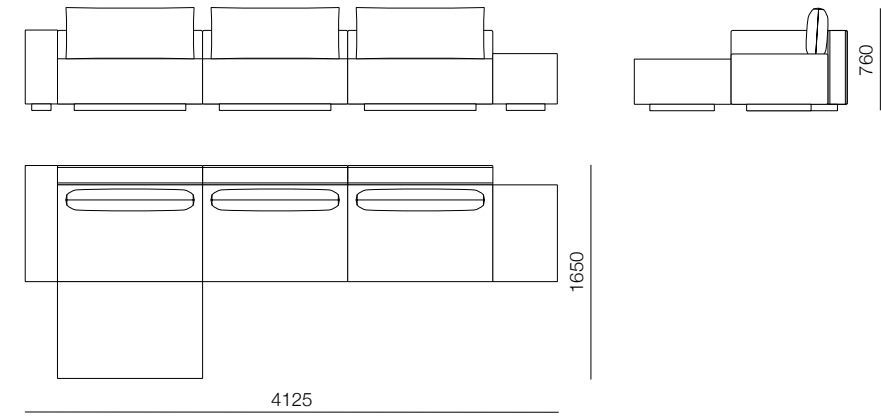

M.47
S_1125 A_H900
B_1125 A_W750
C_1000

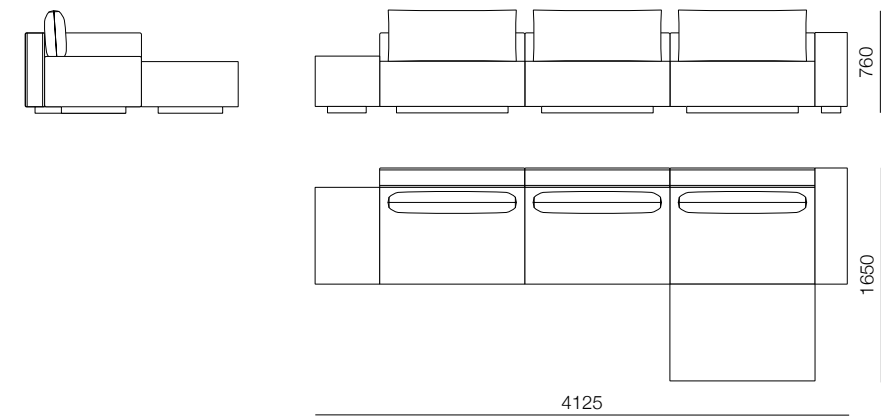

M.48
S_1125 A_H900
B_1125 A_W750
C_1000

_ COMPOSITIONS MODULAR

_1125

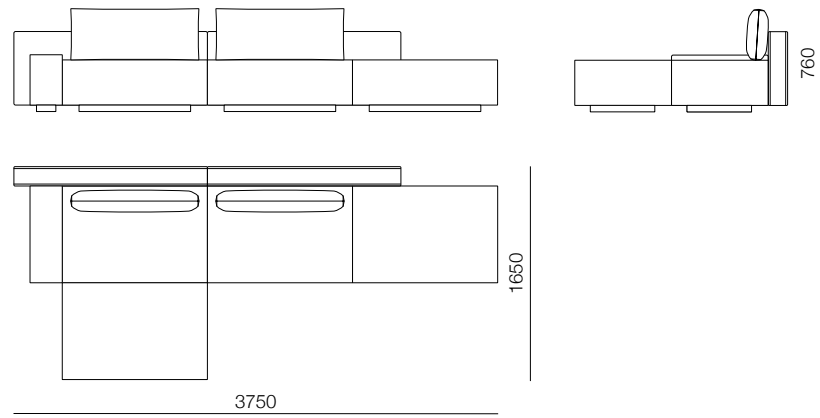

M.49
 S_1125 A_S750
 B_1500
 C_1000

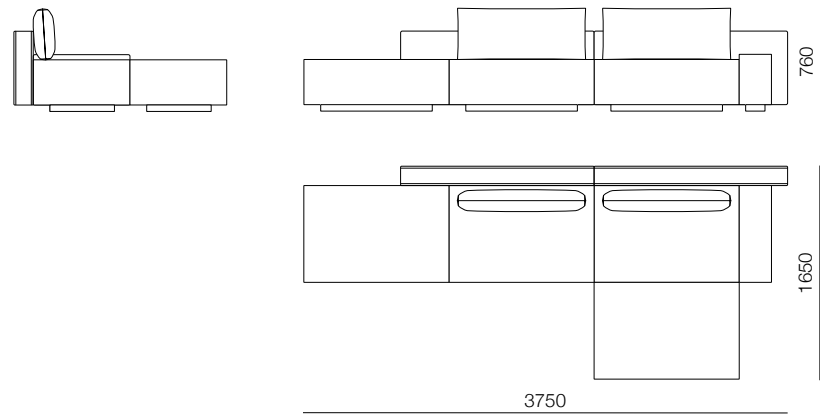

M.50
 S_1125 A_S750
 B_1500
 C_1000

_ COMPOSITIONS MODULAR

_1125



M.51
 S_1125 A_S750
 B_1500
 C_1000

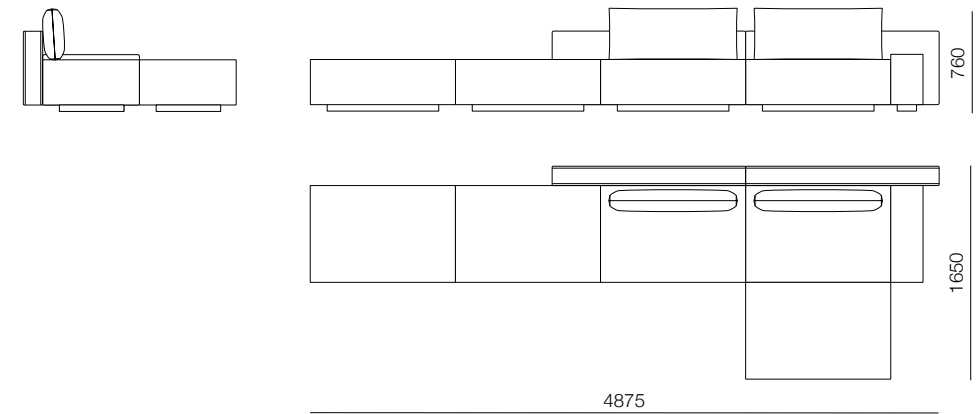

M.52
 S_1125 A_S750
 B_1500
 C_1000

_ COMPOSITIONS_MODULAR

_1125



M.53
S_1125 A_S750
B_1500
C_1000

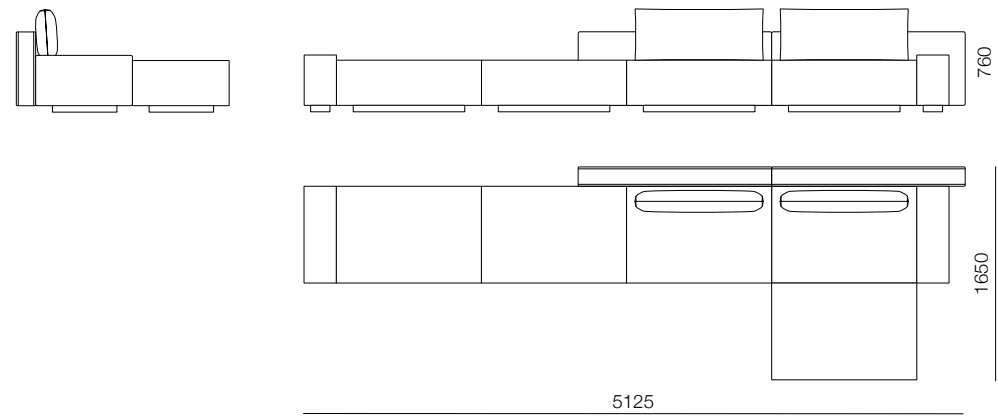

M.54
S_1125 A_S750
B_1500
C_1000

_ COMPOSITIONS_MODULAR

_1500

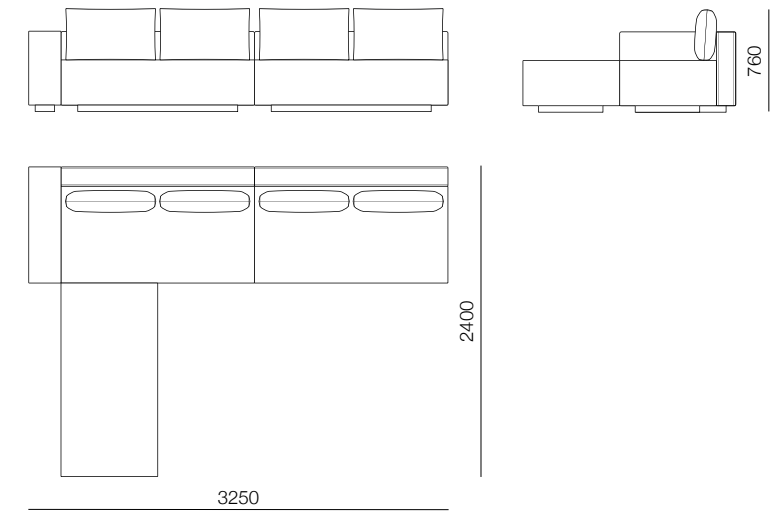

M.55
S_1500 A_H900
B_1500
C_700

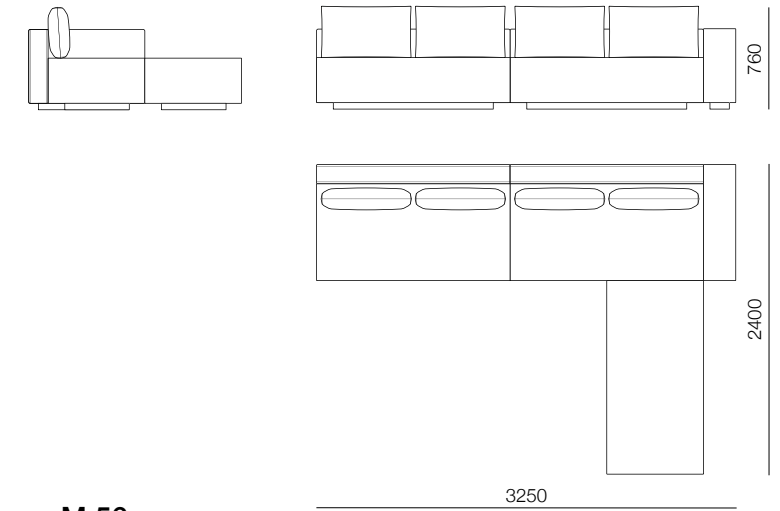

M.56
S_1500 A_H900
B_1500
C_700

_ COMPOSITIONS_MODULAR

_1500

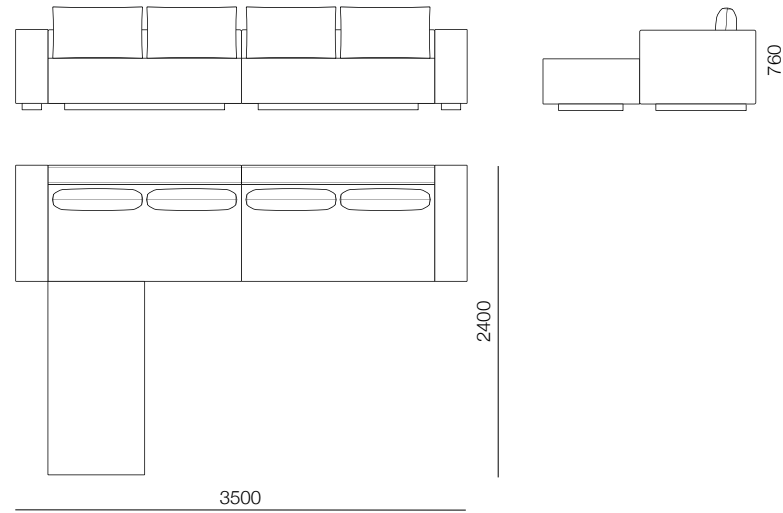

M.57
S_1500 A_H900
B_1500
C_700

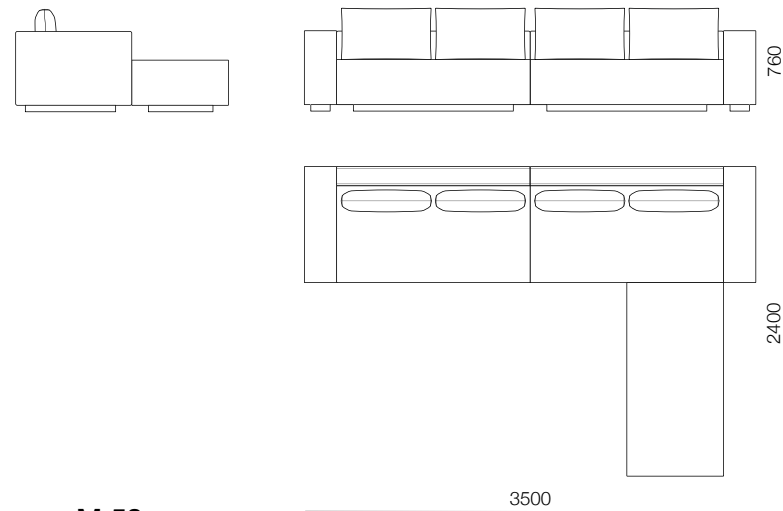

M.58
S_1500 A_H900
B_1500
C_700

_ COMPOSITIONS_MODULAR

_1500

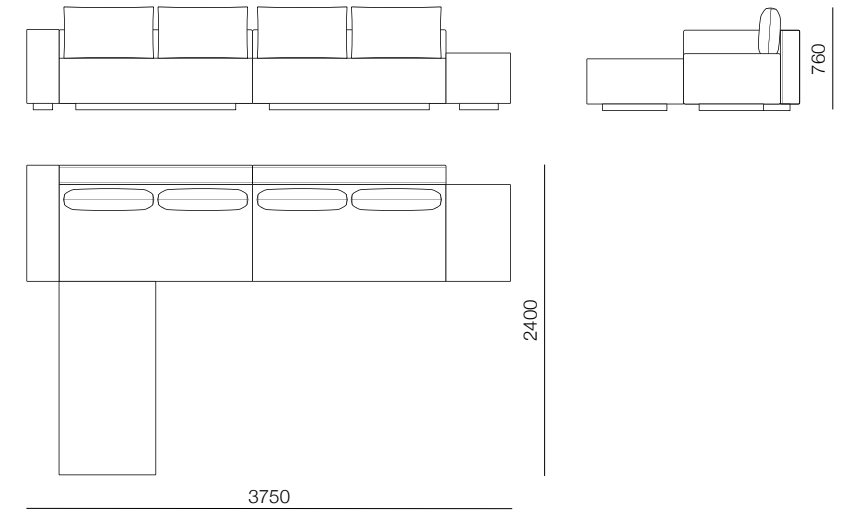

M.59
S_1500 A_H900
B_1500 A_W750
C_700

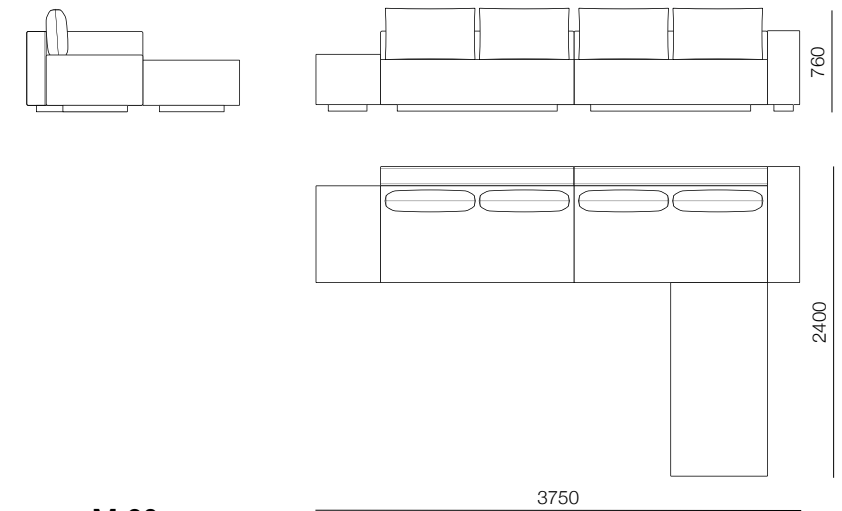

M.60
S_1500 A_H900
B_1500 A_W750
C_700

_ COMPOSITIONS_MODULAR

_1500

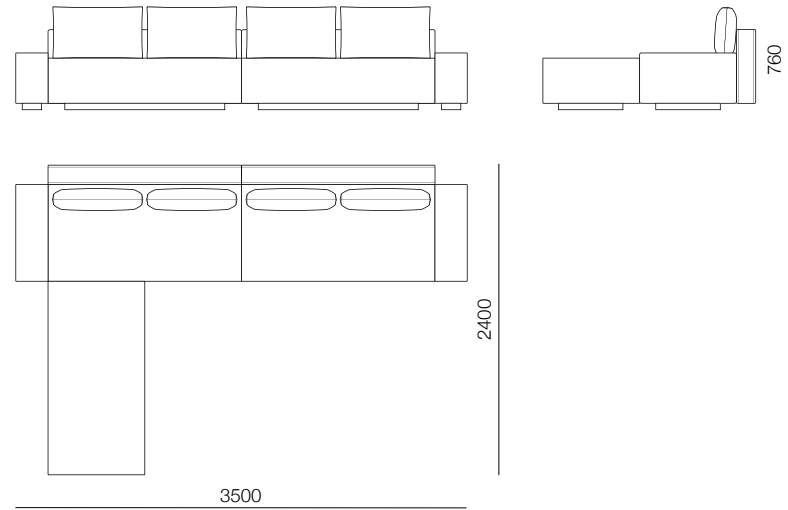

M.61
 S_1500 A_H900
 B_1500
 C_700

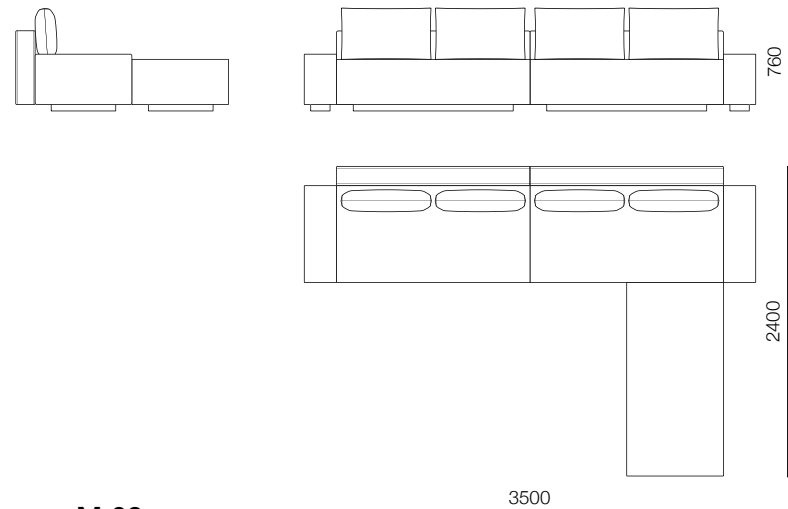

M.62
 S_1500 A_H900
 B_1500
 C_700

_ COMPOSITIONS_MODULAR

_1500

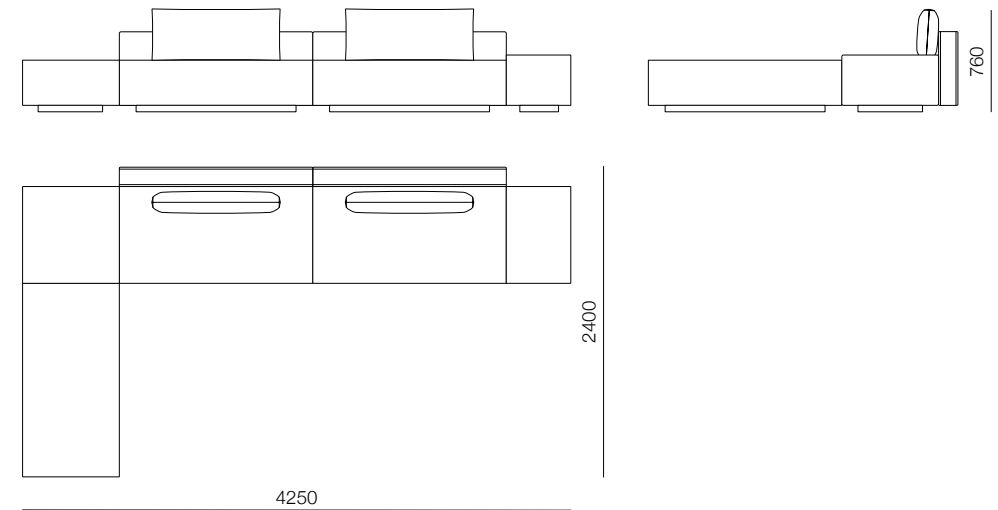

M.63
 S_1500 C_1000
 S_750 A_W750
 B_1500



M.64
 S_1500 C_1000
 S_750 A_W750
 B_1500

_ COMPOSITIONS_MODULAR

_1500

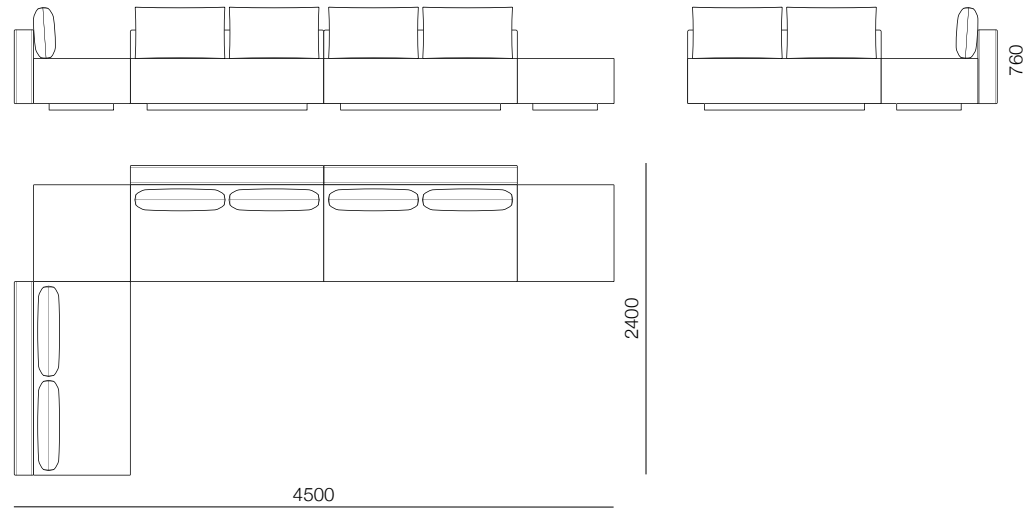

M.65
S_1500 C_700
S_750
B_1500

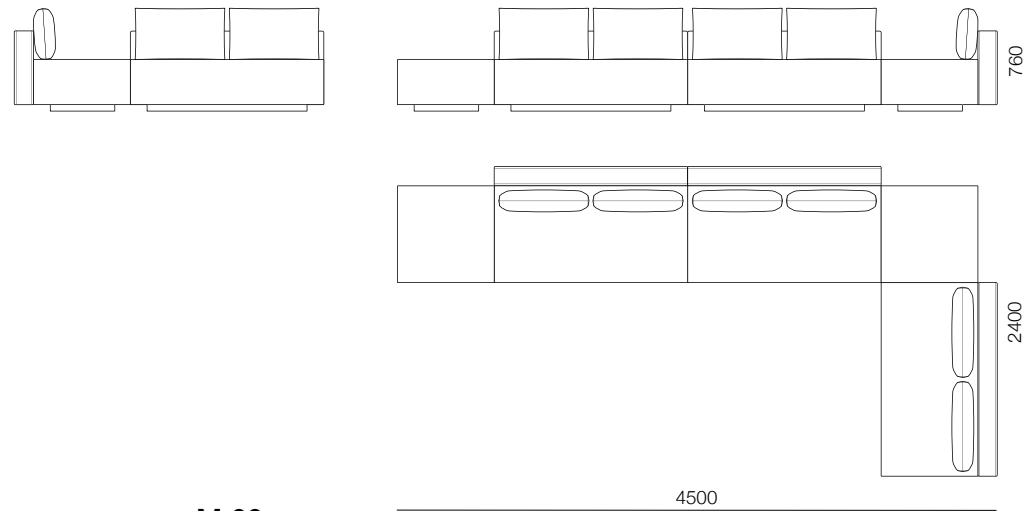

M.66
S_1500 C_700
S_750
B_1500

_ COMPOSITIONS_MODULAR

_1500



M.67
S_1500 C_700
S_750
B_1500

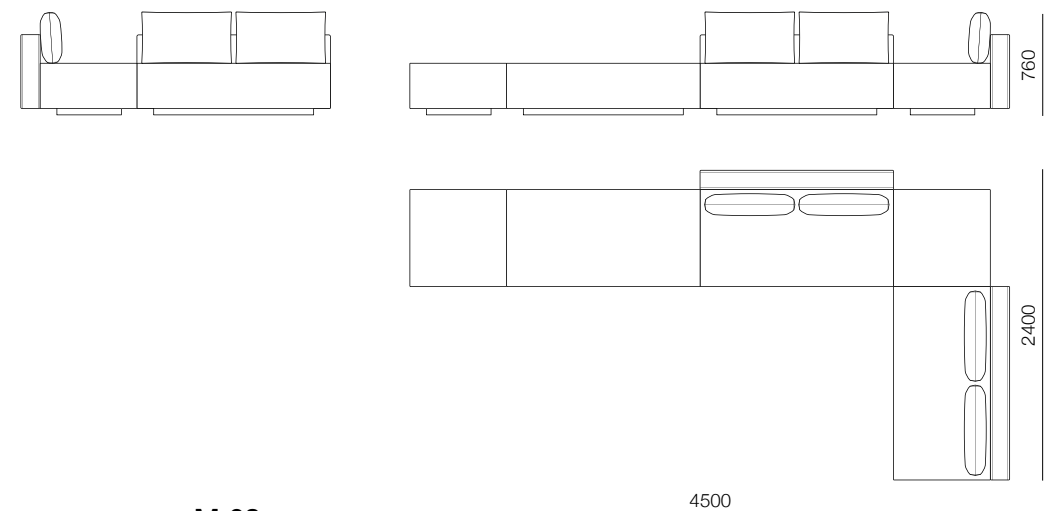

M.68
S_1500 C_700
S_750
B_1500

_ COMPOSITIONS MODULAR

_1500

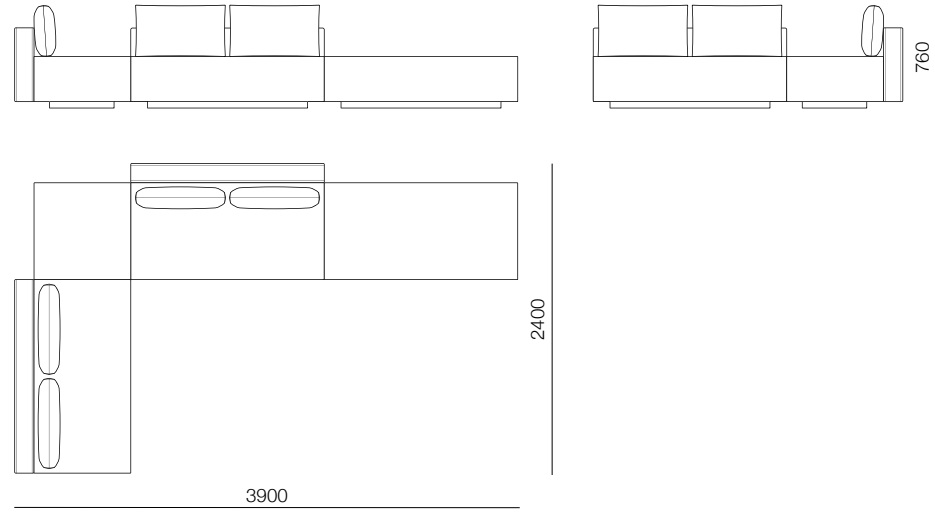

M.69
S_1500 C_700
S_750
B_1500

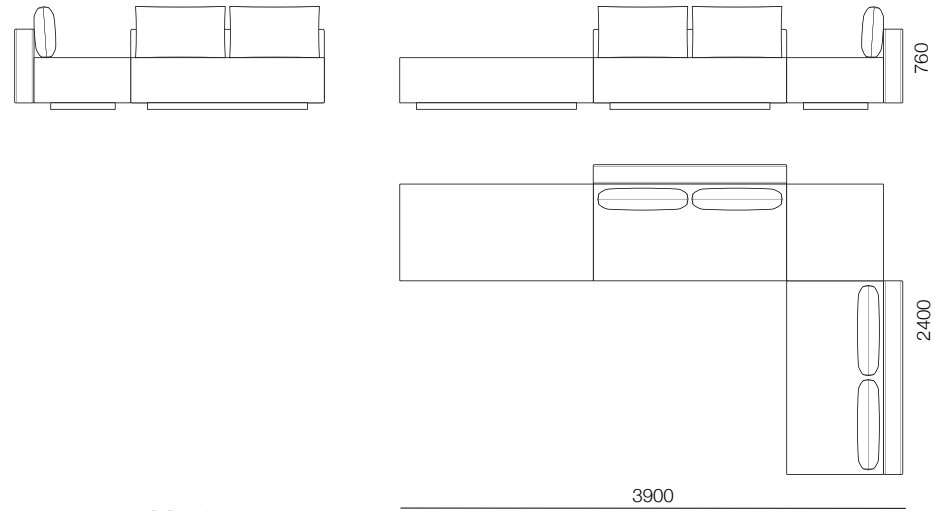

M.70
S_1500 C_700
S_750
B_1500

_ COMPOSITIONS_CORNER MODULAR

_750

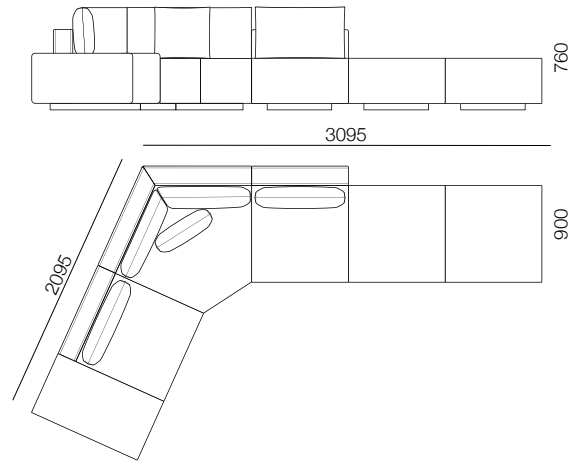

CM.01
S_750 A_W900
B_750 CM_2
C_700

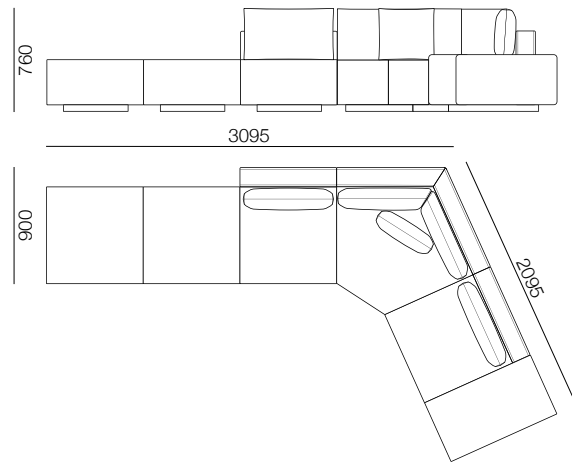

CM.02
S_750 A_W900
B_750 CM_2
C_700

_ COMPOSITIONS_CORNER MODULAR

_750

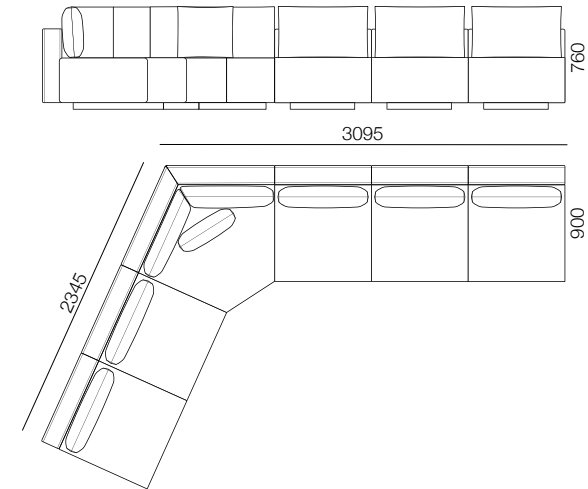

CM.03
S_750 CM_2
B_750
C_700

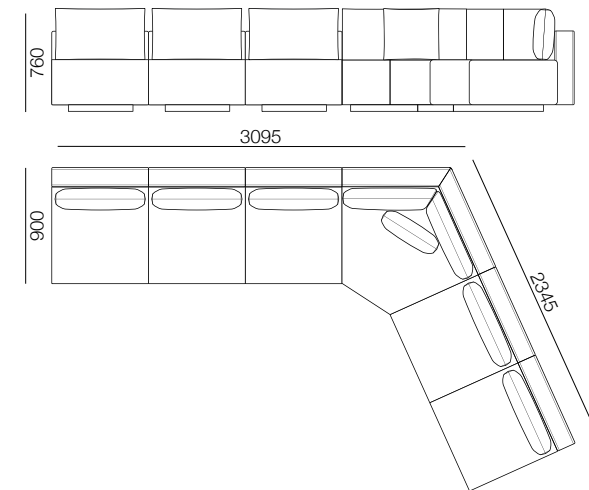

CM.04
S_750 CM_2
B_750
C_700

_ COMPOSITIONS_CORNER MODULAR

_1000

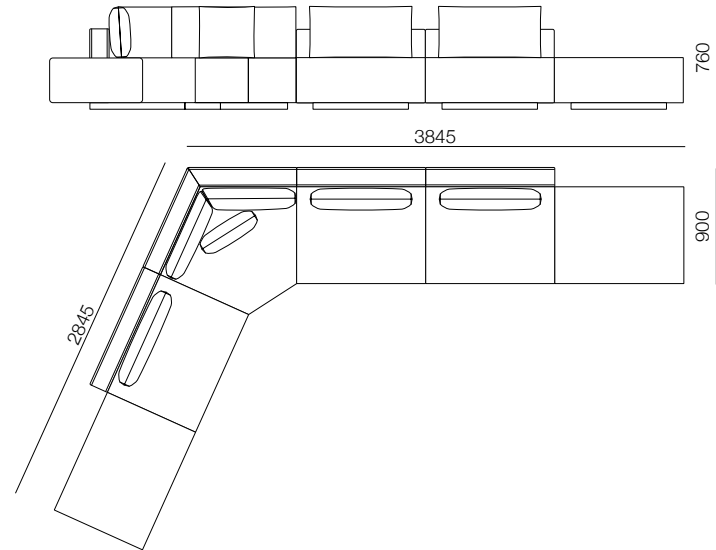

CM.05
S_1000 CM_2
B_1000
C_800

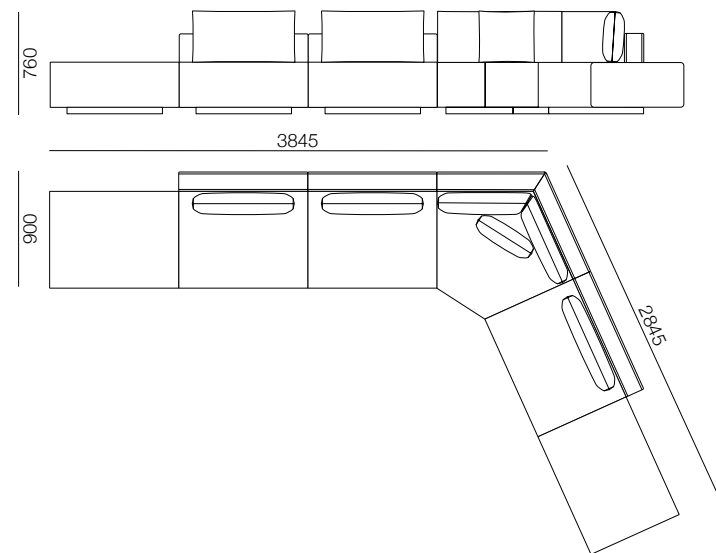

CM.06
S_1000 CM_2
B_1000
C_800

_ COMPOSITIONS_CORNER MODULAR

_1000

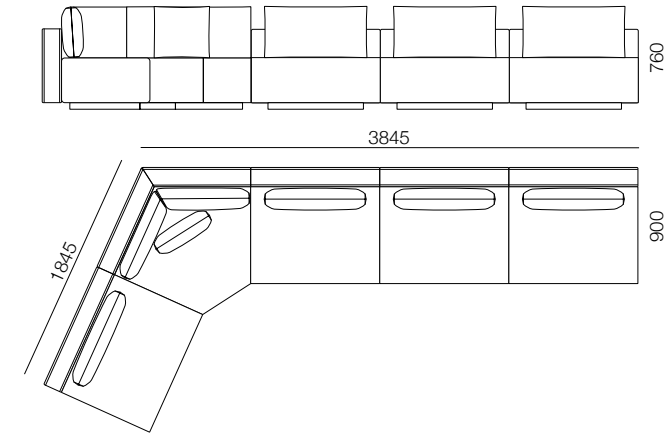

CM.07
S_1000 CM_2
B_1000
C_800

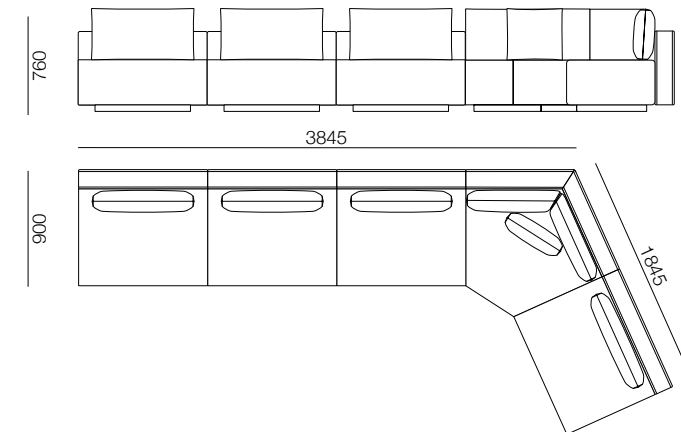

CM.08
S_1000 CM_2
B_1000
C_800

_ COMPOSITIONS_CORNER MODULAR

_1125

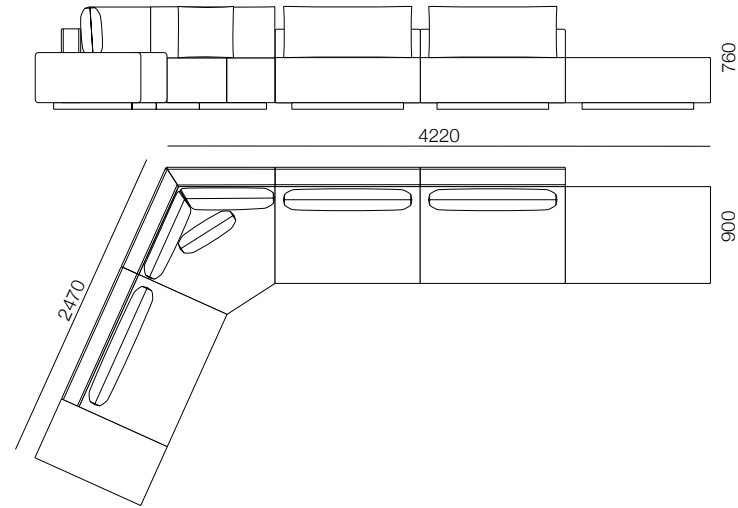

CM.09
S_1125 A_W900
B_1125 CM_2
C_1000

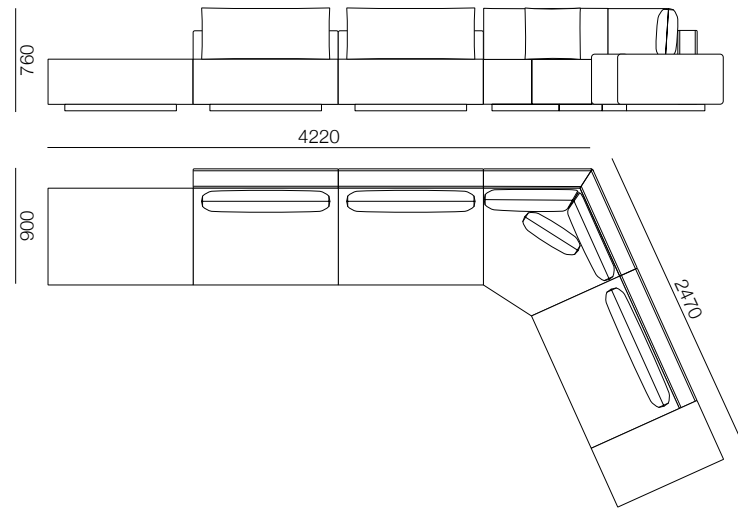

CM.10
S_1125 A_W900
B_1125 CM_2
C_1000

_ COMPOSITIONS_CORNER MODULAR

_1125

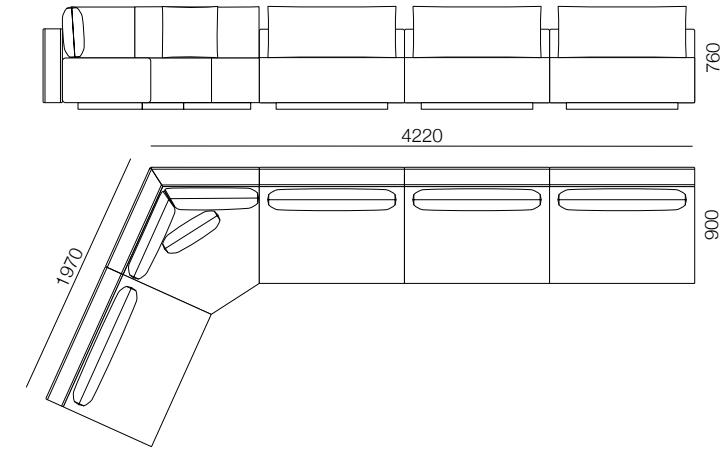

CM.11
S_1125 CM_2
B_1125
C_1000

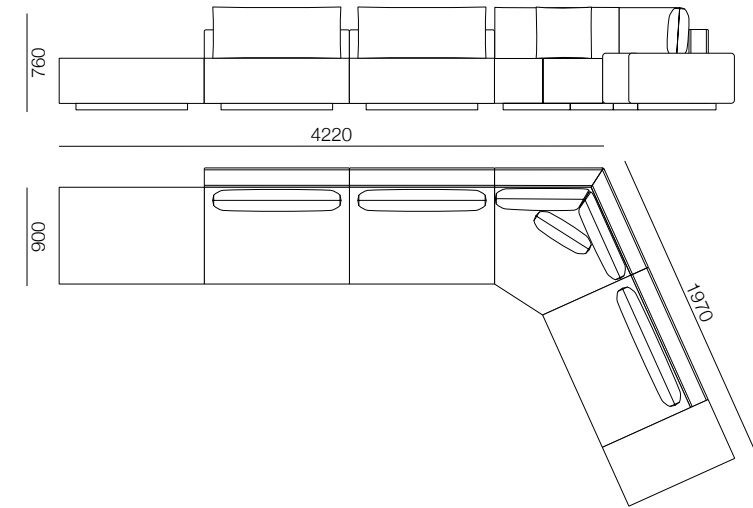

CM.12
S_1125 CM_2
B_1125
C_1000

_ COMPOSITIONS_CORNER MODULAR

_1125

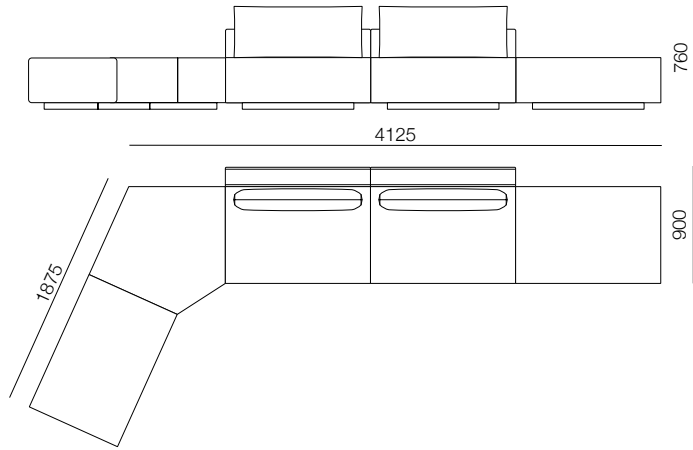

CM.13
S_1125 CM_1
B_1125
C_1000

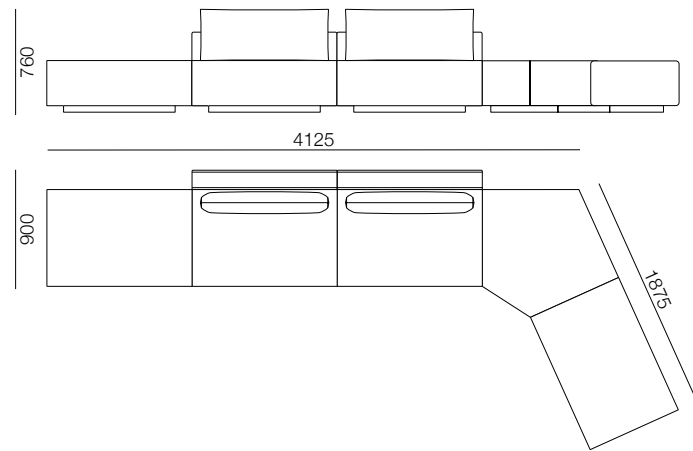

CM.14
S_1125 CM_1
B_1125
C_1000

_ COMPOSITIONS_CORNER MODULAR

_1125

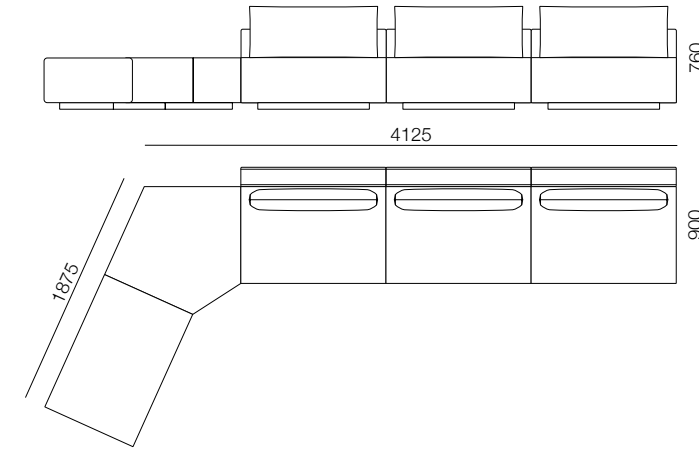

CM.15
S_1125 CM_1
B_1125
C_1000

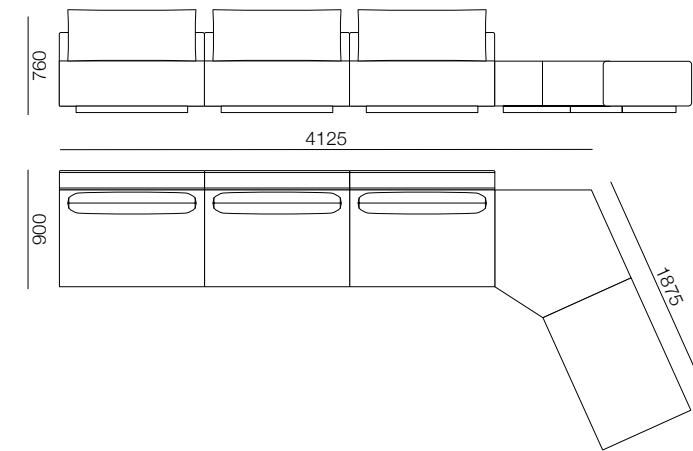

CM.16
S_1125 CM_1
B_1125
C_1000

_ COMPOSITIONS_CORNER MODULAR

_1500

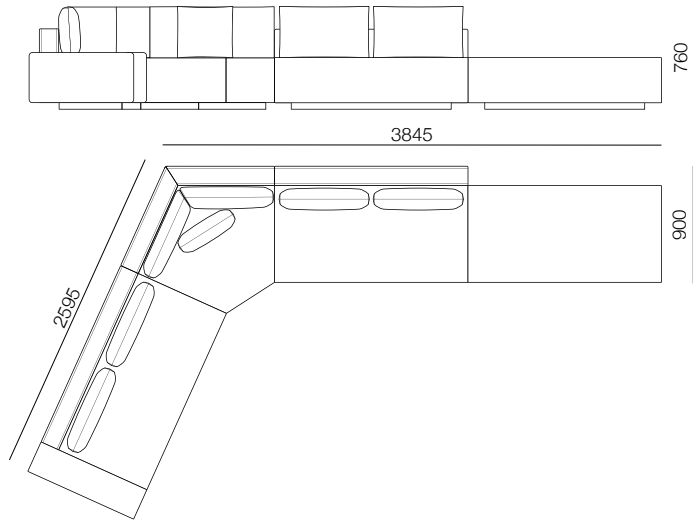

CM.17
S_1500 A_H900
B_1500 CM_2
C_700

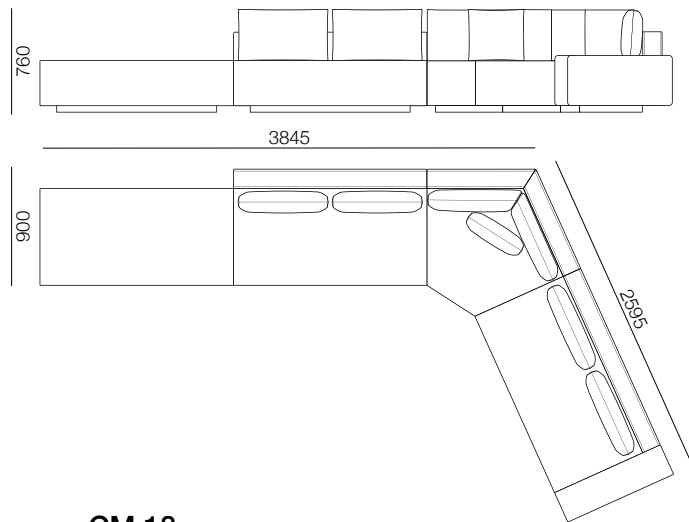

CM.18
S_1500 A_H900
B_1500 CM_2
C_700

_ COMPOSITIONS_CORNER MODULAR

_1500

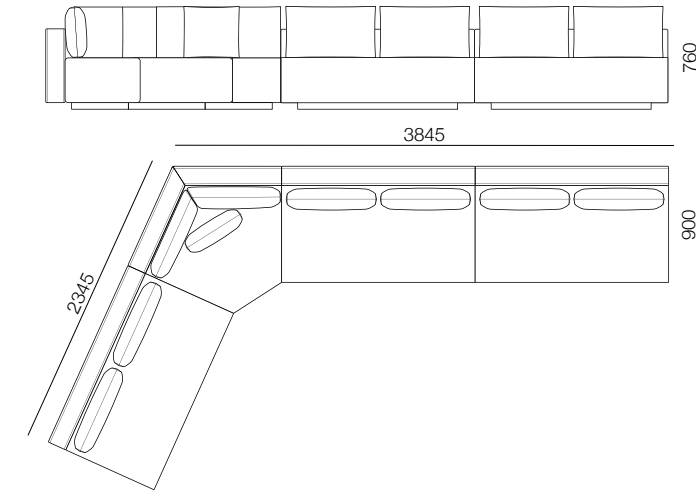

CM.19
S_1500 CM_2
B_1500
C_700

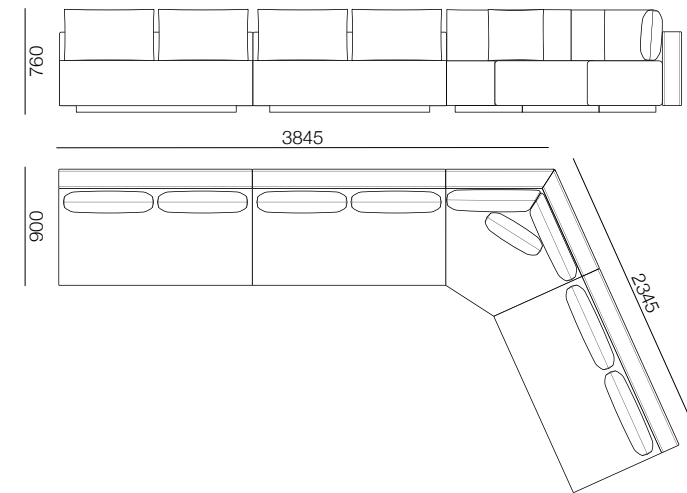

CM.20
S_1500 CM_2
B_1500
C_700