

Autobahn

Just like the German highway, the Autobahn collection is all about flowing lines, open spaces and endless possibilities. A modular seating system allows for ultimate versatility and ease of use. A refined and pared-back form allows Autobahn to effortlessly change gears and adapt to both formal and informal environments.







Autobahn

Information

Design

Alexander Lotersztain, 2012

Environment

Indoor

Warranty

5 year structural

Certifications

GECA certified

Materials

Dunlop Enduro® foam with MDF substrate, upholstered in Customer's Own Material (COM) and/or Leather (COL). Powder coated mild steel legs. Table tops constructed of veneered MDF or laminated structural board with matching ABS edge.

Notes

1. Seating units cannot be used individually.
2. Each seating unit is supplied with a linking plate, used to connect units together.
3. Legs supplied with adjustable feet.

Finishes

Upholstery



Fabric
COM



Leather
COL

Legs



White
Powder Coat



Black
Powder Coat



Custom
Powder Coat

Table Top



American Oak
Veneer



Black Stained
Veneer



White
Laminate



Black
Laminate

Dimensions

Bench

Seat

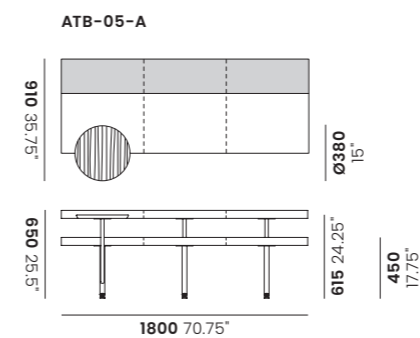
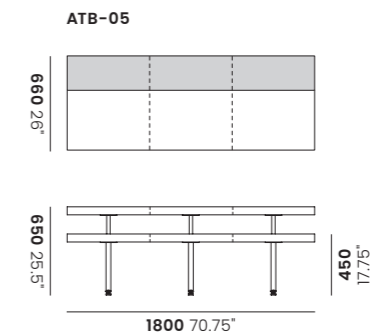
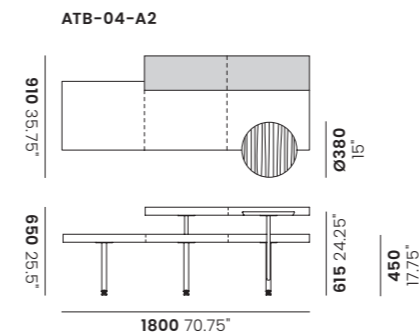
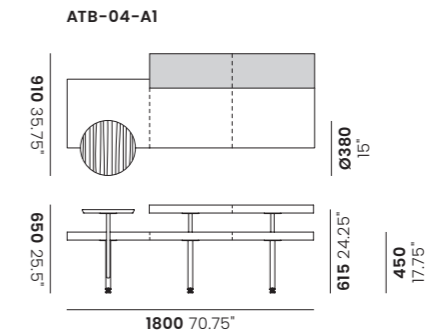
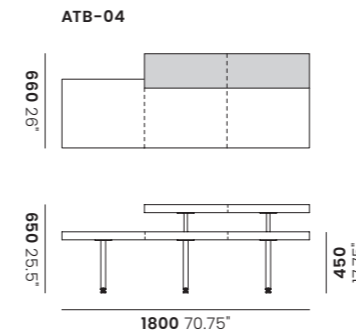
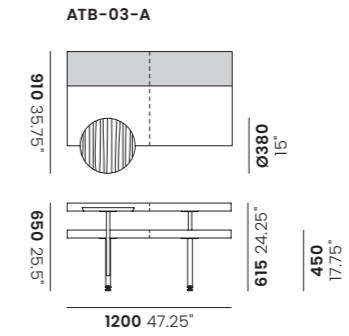
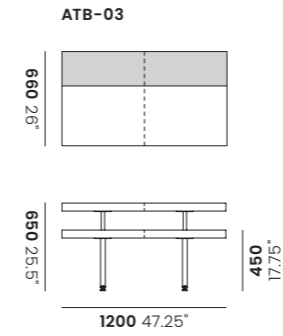
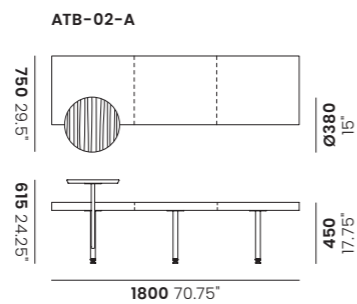
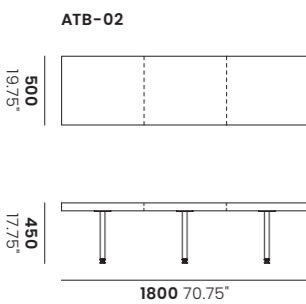
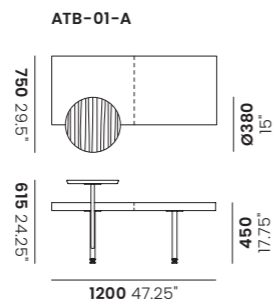
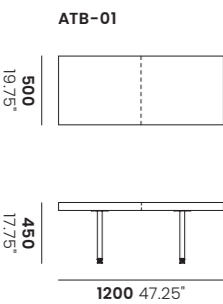

90° Curved Bench

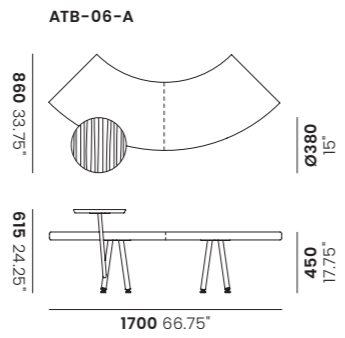
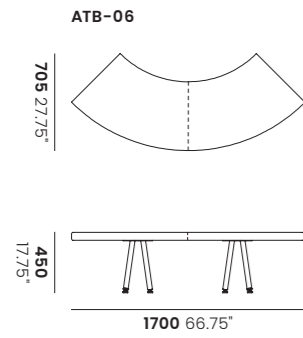

Inner radius: **700** 27.5°
Outer radius: **1200** 47.25°

90° Curved Seat

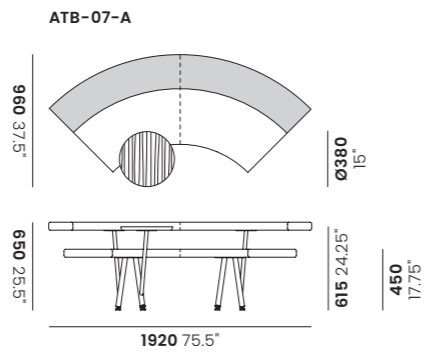
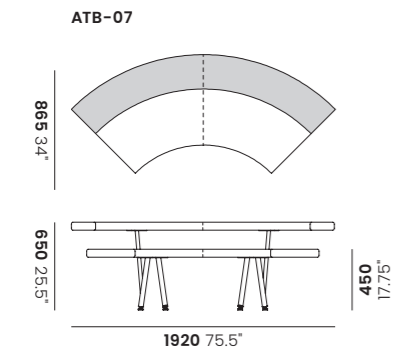

Inner radius: **700** 27.5°
Outer radius: **1360** 53.5°

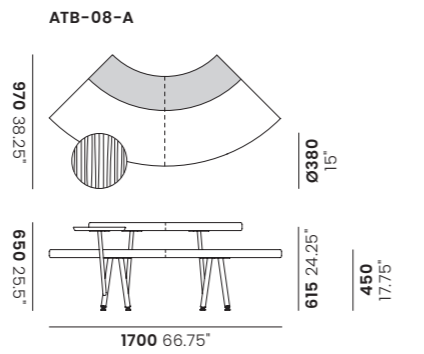
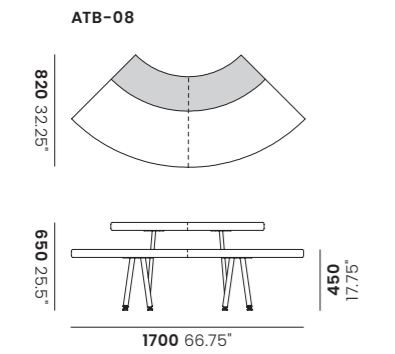

Inner radius: **540** 21.25°
Outer radius: **1200** 47.25°

90° Large Curved Bench

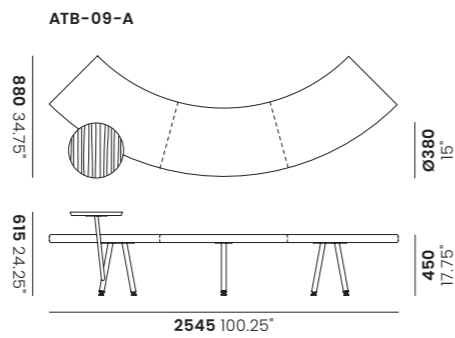
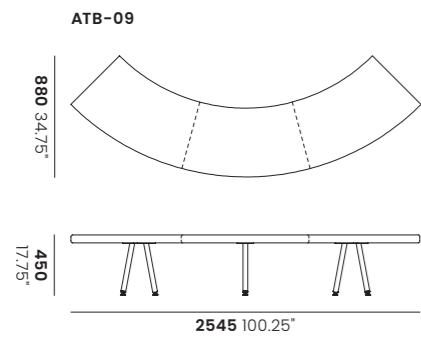

Inner radius: **1300** 51.25°
Outer radius: **1800** 70.75°

90° Large Curved Seat

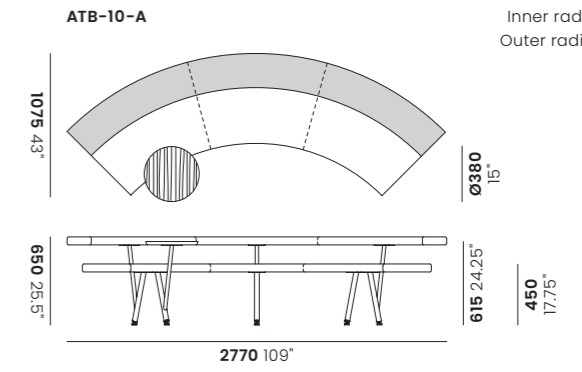
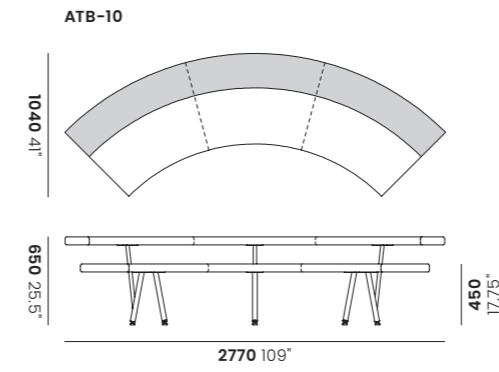

Inner radius: **1300** 51.25°
Outer radius: **1960** 77.25°

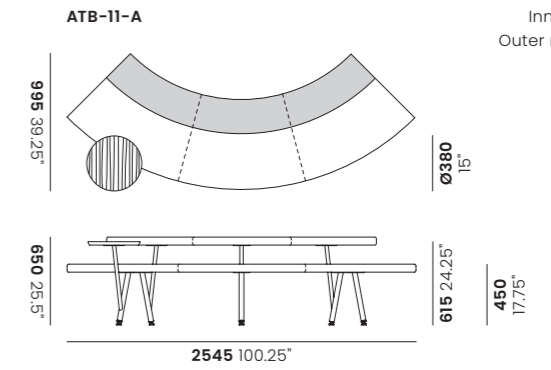
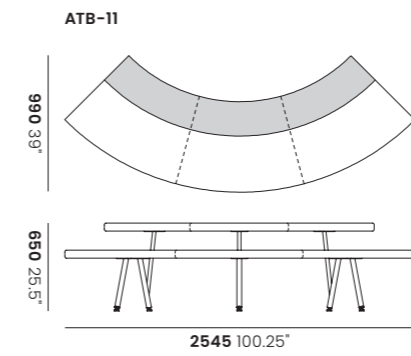

Inner radius: **1140** 45°
Outer radius: **1800** 70.75°

45° Curved Bench

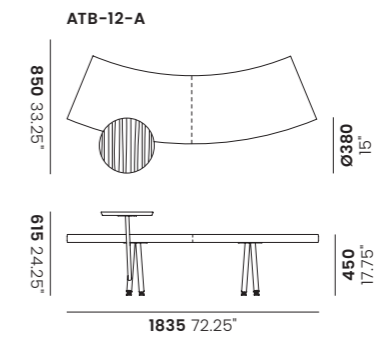
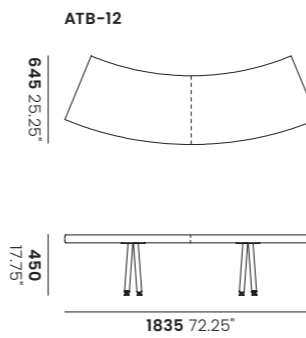

Inner radius: **1900** 74.75°
Outer radius: **2400** 94.5°

45° Curved Seat

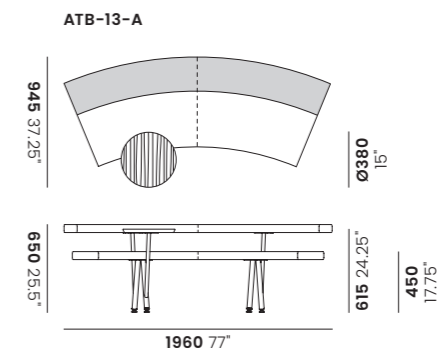
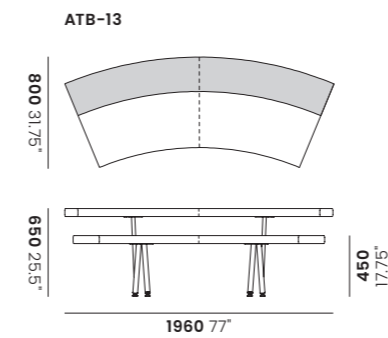

Inner radius: **1900** 74.75°
Outer radius: **2560** 100.75°

45° Curved Seat (Continued)

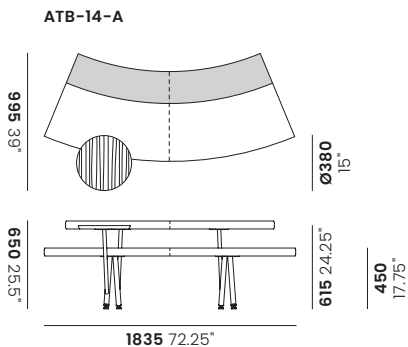
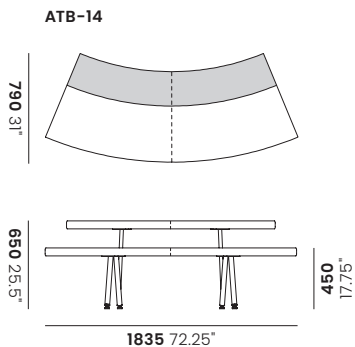

Inner radius: 1740 68.5"
Outer radius: 2400 94.5"

Ottoman

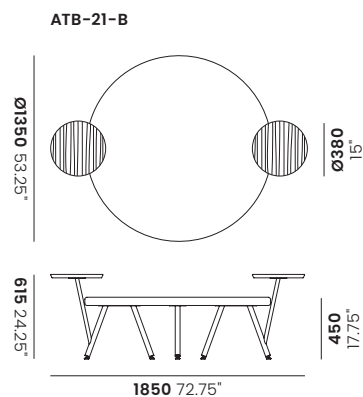
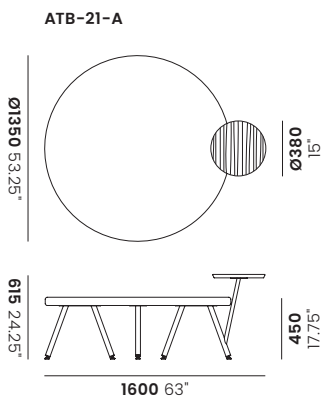
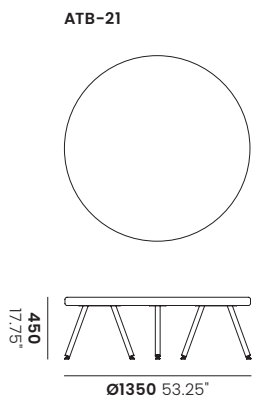

Table

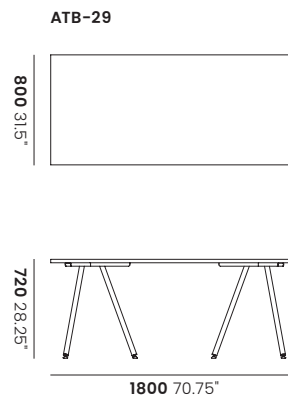
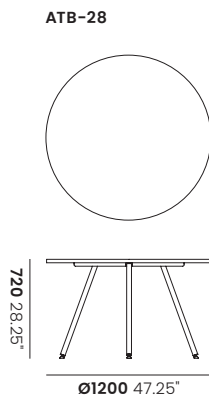
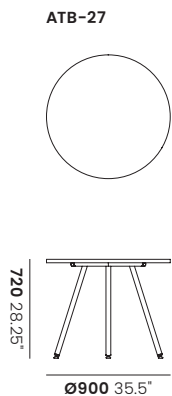
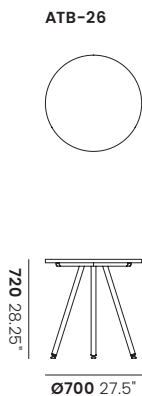

Side Table

